

Spontaflex 550kHz To 30MHz Radio Receiver

Raymond Haigh

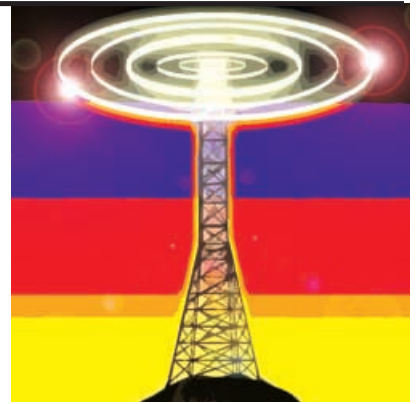

A modern-day update of Sir Douglas Hall's famous Spontaflex reflex circuit

THIS updated version of the Spontaflex receiver is presented with a more powerful single i.c. add-on audio amplifier, extends coverage through the medium wave band, and uses currently available components that are assembled on printed circuit boards. Using just two transistors, the tuner section retains all of the sensitivity of the original design. The set will receive a.m. and s.s.b. signals.

The receiver is assembled on three separate printed circuit boards, comprising a tuner section, a coil pack, and an audio power amplifier. This arrangement has been adopted so that readers can more easily modify the design to suit their own requirements, or to use coils and an amplifier already to hand.

Tuner Section

The combined circuit diagram of the Tuner and Coil Pack stages is shown in Fig.1. With the audio output emerging at the "earthy" end of the radio frequency input attenuator, its functioning is obscure, even by reflex radio standards. Perhaps the best way to unravel it is to follow the signal path.

Regenerative receivers are easily overloaded by strong signals, so an Input Attenuator control is provided by potentiometer VR1. The injection of low frequencies into the audio signal path is inhibited by capacitor C2, with capacitor C4 limiting the effect of aerial loading on the tuning and regeneration controls.

Signals picked up by the aerial are applied, via C4, to the emitter (e) of TR1. This transistor functions as a grounded base amplifier at radio frequencies, and chokes RFC1 and RFC2 act as the collector (c) load. The base (b) is "grounded" by capacitor C6.

The radio frequency output from transistor TR1's collector (c) is applied to the base (b) of TR2 via d.c. blocking capacitor C7. At radio frequencies, transistor TR2 is configured as a common collector (or emitter follower) stage. Its

collector is grounded at radio frequencies by capacitor C6, and diode D1 rectifies the output at TR2's emitter in order to recover the audio modulation from the signal. This common collector arrangement results in a comparatively high impedance at TR2's base, and direct connection to the tuned circuit is permissible. (Damping is overcome by *Q* multiplication or regeneration – see later).

Audio Frequencies.

The audio signal voltage, developed across diode D1, is injected automatically at the emitter of TR2 which now functions as a grounded base amplifier. The base of this transistor is grounded, at audio frequencies, via the tuning coil (selected by rotary switch S1b) and capacitor C5. The audio signal, developed across TR2's collector load resistor (presets VR2 to VR6, wired as variable resistors), is connected directly to the base of TR1, which operates as a common collector amplifier at audio frequencies.

Audio output at TR1's emitter is developed across load resistor R2, and capacitor C3 shunts unwanted radio fre-

quencies. Blocking resistor R1 prevents the shorting of the radio frequency input by this capacitor.

Deploying transistors in the common collector mode, which gives current amplification but no voltage amplification, and the grounded base mode, which provides voltage amplification but no current amplification, is unusual. However, the high input and low output impedances of common collector stages are matched to the low input and high output impedances which result when the transistors are configured in the grounded base mode, and overall gain is high. This, coupled with the dramatic increase in efficiency afforded by regeneration, gives the receiver its high sensitivity.

Tuning - In

The receiver is tuned to the desired frequency by one of the switched coils L1 to L5 and bandset (Tuning) variable capacitor VC1. Tuning, especially on the higher frequency shortwave bands, is critical, and a low-value bandspread (Fine Tune) variable capacitor, VC2, makes it easier to adjust the receiver. Series capacitor C8 reduces the effective swing of VC2 to make its action even gentler.

Some readers may not want multi-band operation and the complication it brings, or they may wish to experiment with the tuner before embarking on the construction of the full receiver. Details of simpler, single band tuning arrangements are given later.

Regeneration

A technique known as *regeneration* can enhance the sensitivity and selectivity of simple receivers and make them responsive to extremely weak signals. It involves the use of controlled positive feedback to dramatically increase the *Q*-factor of the tuning coil and capacitor combination. Signal magnification is directly related to tuned circuit *Q*, and the performance of the receiver is enormously improved.

For greatest sensitivity and selectivity, the circuit has to be held close to the onset

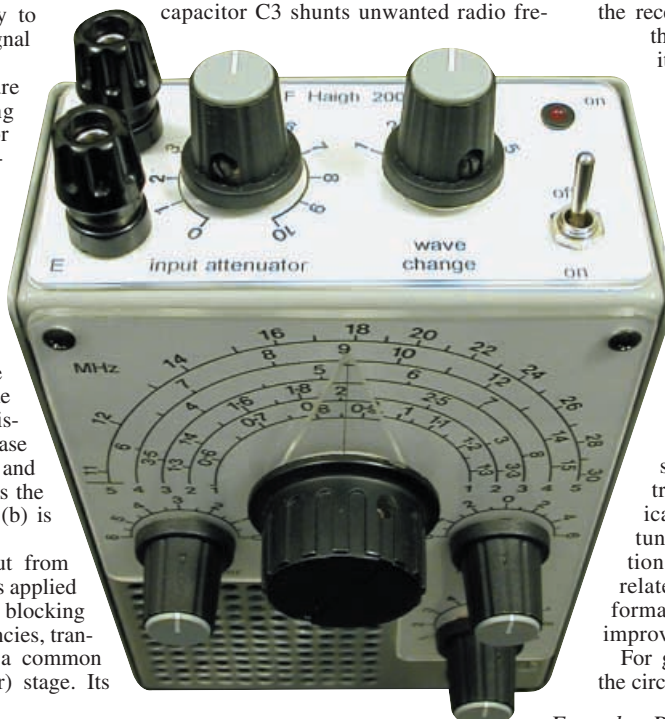

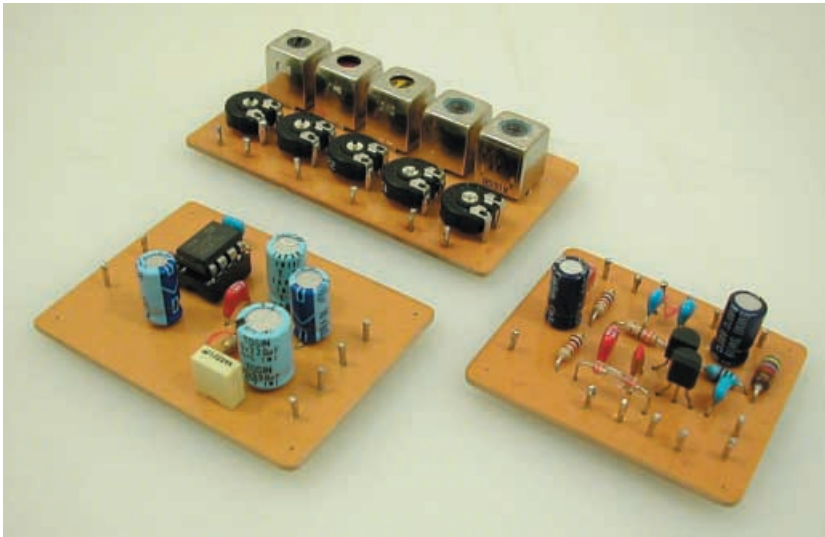

The three main circuit boards that make up the Spontaflex Receiver: Coil Pack (top), Audio Amp (left) and Tuner (right)

Choked-Up

Similarly, two radio frequency (r.f.) chokes, RFC1 and RFC2, are connected in series to ensure consistent performance across the tuning range. The higher inductance 4.7mH choke is required to ensure smooth regeneration at frequencies below 1MHz. Readers who do not wish to use the receiver for medium wave reception can dispense with this component, but remember to insert a wire link in its place on the printed circuit board.

Bypass capacitor C9 prevents instability

with ageing batteries when the Tuner is used as a stand-alone unit. If the Tuner is connected to an audio amplifier, and both units are powered by the same battery, connect the tuner to the power supply via a one kilohm (1k Ω) decoupling resistor. Provision is made for this resistor (R3) on the printed circuit board of the amplifier to be described later. Failure to include it will result in erratic regeneration and "motor-boating" (low frequency instability).

Audio Output

The Audio output signal is taken from

the emitter of transistor TR1 via d.c. blocking capacitor C1. A small value is quoted for this component in order to attenuate the lower audio frequencies.

The signal voltage developed across resistor R2 will produce a clearly audible output from a crystal earpiece. These units, which rely on the piezoelectric effect, are very sensitive and present a high impedance to the signal source. Walkman type earphones are *not* suitable for direct connection to the Tuner.

Components

The transistor used in the TR2 position must be capable of operating at a low collector current. The 2N3707 is the device specified, but a 2SC458, which has the same lead arrangement, has been "set tested" and found to perform equally well. Substituting a BC173 results in a barely perceptible reduction in sensitivity, but it is certainly an acceptable substitute.

Most small signal, high gain, *npn* transistors, e.g., the BC549C, will function acceptably in the TR1 position. Transistors specially manufactured for use at radio frequencies, e.g., the BF494, are *not* suitable for use in this circuit.

A diode with a relatively high forward resistance is required. The original circuit used an OA81 *germanium* diode, but an OA91 is equally suitable. Although not "set tested", an OA85 or an AA117 should also work in this circuit. An unsuitable diode will reduce sensitivity and inhibit regeneration above 10MHz.

Tuning Coils

Consisting of a single, untapped winding, the tuning coils couldn't be simpler and almost any inductor of appropriate value should prove suitable.

COMPONENTS

Approx. Cost
Guidance Only

£25

excl. case and
batts

TUNER		See SHOP TALK page
Resistors		
R1	330 Ω	
R2, R3	1k (2 off)	
All 0.25W 5% carbon film		
Potentiometers		
VR1	4k7 rotary carbon, lin	
VR2	1M enclosed carbon preset, horiz.	
VR3	470k enclosed carbon preset, horiz.	
VR4	220k enclosed carbon preset, horiz.	
VR5	100k enclosed carbon preset, horiz.	
VR6	47k enclosed carbon preset, horiz.	
Capacitors		
C1	470n ceramic	
C2	1n ceramic	
C3	100n ceramic	
C4	100p ceramic	
C5, C9	100 μ radial elect. 16V (2 off)	
C6	1n5 ceramic or polyester	
C7	22p ceramic	
C8	15p ceramic	
VC1	10p to 260p (two a.m. gangs of a 4-ganged a.m./f.m. polyvaricon connected in parallel)	
VC2	5p to 25p (one f.m. gang of a 4-ganged a.m./f.m. polyvaricon)	
VC3	5p to 60p or 5p to 140p (one gang of a 2-ganged a.m. only polyvaricon - see text)	

Semiconductors

D1	OA91 germanium diode
TR1, TR2	2N3707 <i>npn</i> transistor (2 off)

Miscellaneous

L1	RWR331208 Toko coil
L2	154FN8A6438 Toko coil
L3	154FN8A6439 Toko coil
L4, L5	KXNK3766 Toko coil (2off)
RFC1	1mH min. ferrite-cored r.f. choke
RFC2	4m7H min. ferrite-cored r.f. choke (only required for reception below 1MHz - see text)
S1	2-pole 6-way rotary switch

Printed circuit boards available from the *EPE PCB Service*, codes 494(Tuner), 495(Coil) and 406 (Tune Cap - 3 off, see text); metal case, size and type to choice; epicyclic slow-motion drive; one large and four small plastic control knobs; screw terminals (2 off) for Aerial and Earth; white card, rub-down lettering and small piece of 2mm transparent acrylic sheet for front panel dials; stick-on rubber feet connecting wire; p.c.b.-mounting stand-offs; solder pins; nuts, bolts and washers; solder etc.

If the Tuner is to be used as a stand-alone unit you will need a small metal or plastic case, a crystal earpiece and a jack socket to match.

For single-band (6MHz to 16MHz) tuning coil: 6mm (1/4in.) diameter coil former. Use an off-cut from a *plastic* potentiometer spindle. A short length of 32s.w.g. (30a.w.g.) enamelled copper wire for winding the coil (wire gauge is not critical).

A very inexpensive coil, consisting of 30 turns of 32s.w.g. (30a.w.g.) enamelled copper wire, wound side-by-side on a short length of 6mm (1/4in.) plastic potentiometer spindle off-cut, will give coverage from approximately 6MHz to 16MHz. Wire gauge is not critical. This is a busy segment of the shortwave spectrum and one over which the receiver performs well. Details of a simplified tuning arrangement, using this coil, are given in Fig.9.

Unscreened inductors are not suitable for a switched coil pack unless provision is made for shorting out any coils not in use. Tuned by self-capacitance, they resonate within the frequency range of the coil in circuit, and this causes regeneration dead spots. The screening cans of the specified Toko coils avoid this problem. Moreover, their inductance can be varied over fairly wide limits, making it easy to adjust the receiver for continuous coverage.

Audio instability problems were encountered when attempts were made to tune the original receiver over the medium wave band. This was attributed to the greater d.c. resistance of the medium wave coil, and the problem does not arise with the Toko component. The additional 4.7mH radio frequency choke, RFC2, must, however, be fitted, or performance at the low frequency end of the medium wave band will be erratic.

Audio Power Amplifier

Small, inexpensive, and highly efficient audio power amplifier i.c.s, capable of low-distortion and high gain, have become commonplace since Sir Douglas published his reflex designs. His single transistor output stage, intended for earphone listening and the low-level speaker reproduction of strong signals, has been replaced by a TBA820M audio amplifier i.c. The complete circuit diagram for this simple Audio Power Amplifier is given in Fig.2.

Audio signals from the Tuner are applied, via the moving contact (wiper) of Volume control potentiometer VR1, to the input (pin 3) of IC1. Note that the required input d.c. blocking capacitor is located on the Tuner printed circuit board (C1). Readers wishing to use this amplifier with other equipment should inject the signal via a 4.7µF electrolytic capacitor (negative lead to VR1).

Bypass capacitors C1 and C2 ensure stability at audio and radio frequencies. The overall gain of the circuit is fixed, by resistor R1, at 230 times (47dB), and response to higher audio frequencies is curtailed by increasing the value of feedback capacitor C5 to 680pF. This measure makes externally and internally generated electrical noise much less intrusive.

The Zobel network, formed by resistor R2 and capacitor C6, prevents damage being caused to the on-chip output transistors by transient, high-level signals. Blocking capacitor C7 couples the amplifier to the loudspeaker LS1. Headphone listening is obtained via jack socket SK1, which automatically takes the speaker out of circuit as the headphones are plugged in. As with the input blocking capacitor, the value of capacitor C7 has been reduced to limit output at low frequencies and avoid overloading the miniature speaker.

Readers who require a flat response should reduce the value of C5 to 220pF and increase C7 to 1000µF. If the amplifier is to be used only with 32 ohm Walkman type headphones, greater speech clarity can result if the value of C7 is further reduced to 22µF, or even 10µF.

Ripple on the power supply rail is rejected by capacitor C4, and the tuner supply is decoupled by resistor R3. The associated decoupling capacitor (C9) is located on the Tuner board.

A low current l.e.d., (D1) together with dropping resistor R4, gives a visual On indication, and S1 is the On/Off switch.

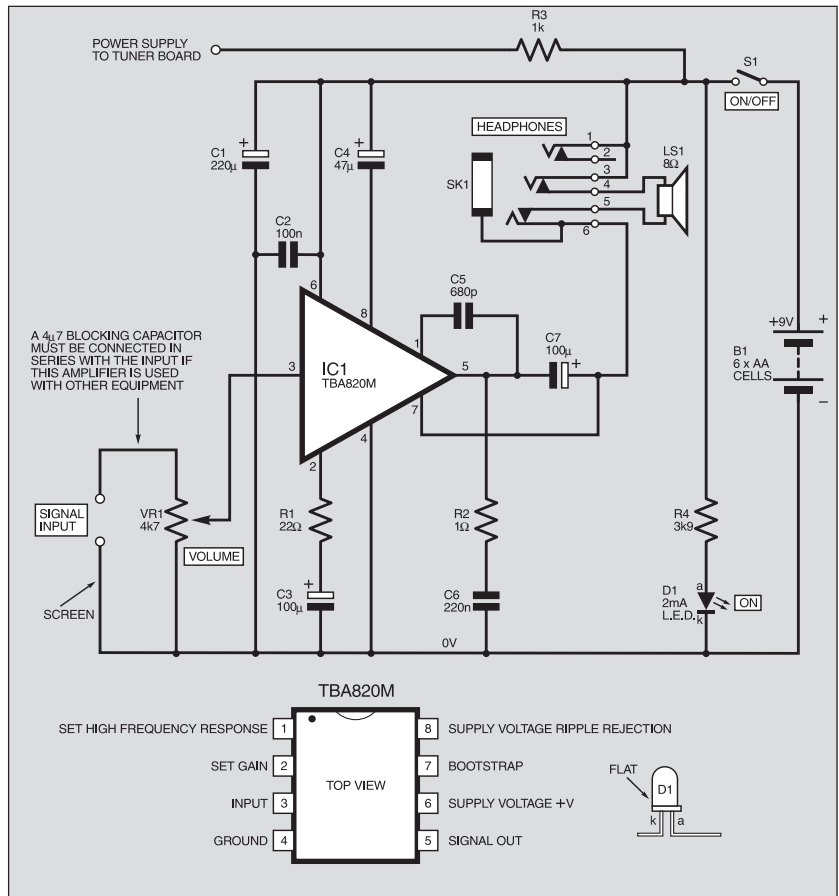

Fig.2. Circuit diagram for the add-on Audio Power Amplifier. The component values for capacitors C5 and C7 have been chosen to restrict the frequency response of the amplifier – see text

COMPONENTS

Approx. Cost
Guidance Only

£9

excl. speaker, case and batts

AUDIO AMPLIFIER		Semiconductors
Resistors		D1
R1	22Ω	5mm low current (2mA) l.e.d., red
R2	1Ω	IC1
R3	1k	TBA820M audio power amp
R4	3k9	Miscellaneous
All 0.25W 5% carbon film		LS1
Potentiometer		S1
VR1	4k7 rotary carbon, log.	SK1
Capacitors.		
C1	220µ radial elect. 16V	
C2	100n ceramic	
C3, C7	100µ radial elect. 16V (2 off)	
C4	47µ radial elect. 16V	
C5	680p ceramic	
C6	220n polyester	

Printed circuit board available from the EPE PCB Service, code 496(Amp); 8-pin d.i.l. socket; p.c.b. stand-off pillars; l.e.d. bezel; small plastic knob; battery holder (6 x AA cells); multistrand connecting wire; nuts, bolts and washers; solder pins; solder etc.

Construction

The Tuner, Coil Pack and Audio Power Amplifier are assembled on individual printed circuit boards (p.c.b.s). The topside component layouts and underside copper foil masters of the Tuner and Coil Pack boards are shown in Fig.3 and Fig.4. The wiring to the wavechange switch and variable capacitors, is illustrated in Fig.5. Readers wishing to dispense with the coil pack should refer to Fig.9, which gives details of a simple, single coil arrangement.

The component layout of the Power Amplifier p.c.b., full-size underside copper foil pattern and the wiring to the off-board Volume control and loudspeaker, are shown in Fig.6 and Fig.7.

Solder pins at the lead-out points on the p.c.b.s help to make off-board wiring easier. They should be inserted first, followed by a 8-pin d.i.l. socket for the power amplifier i.c.

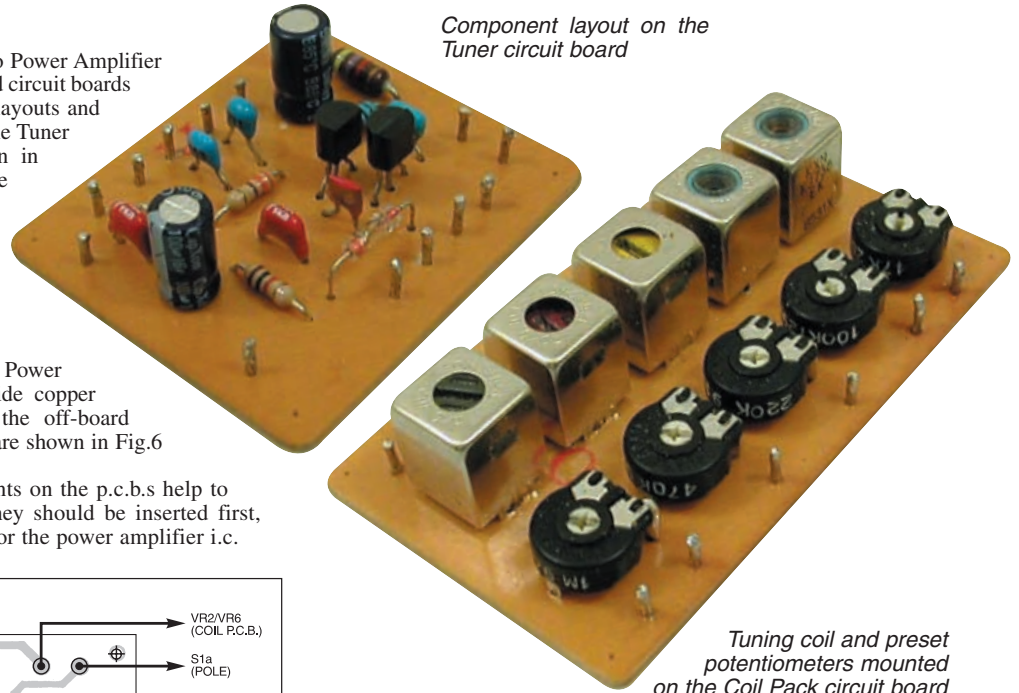

Component layout on the Tuner circuit board

Tuning coil and preset potentiometers mounted on the Coil Pack circuit board

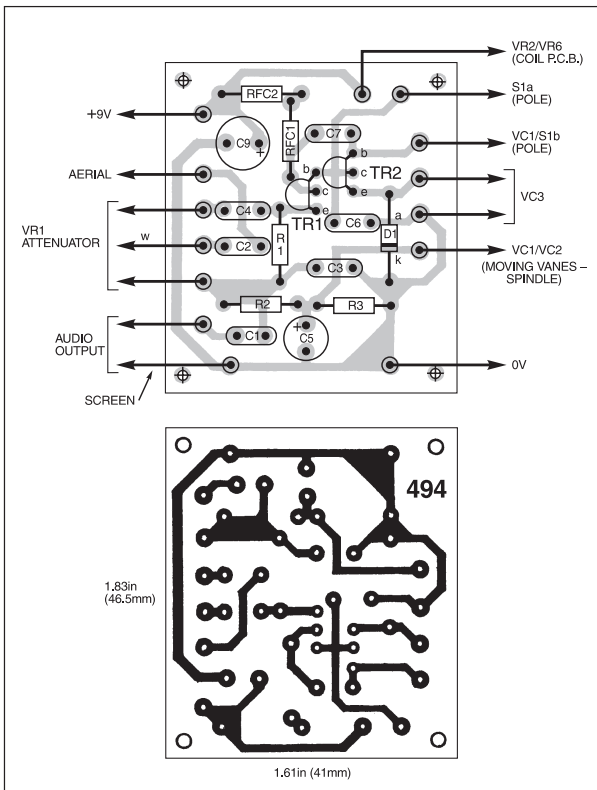

Fig.3. Tuner printed circuit board component layout (excluding coils, presets and wavechange switch), lead-off wires and full-size underside copper foil master. A screened lead must be used for the output lead. Note capacitor C8 is mounted directly between the tuning capacitor p.c.b.s

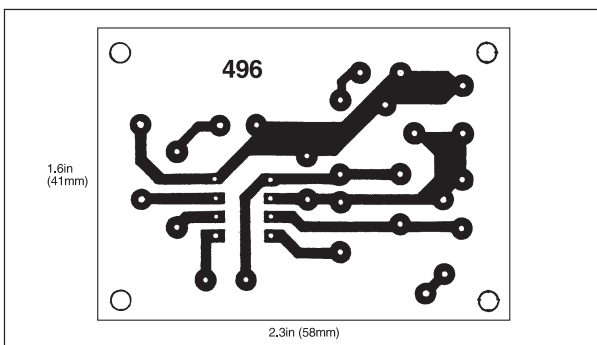

Fig.6. Full-size copper foil master pattern for the simple TBA820 i.c. Audio Power Amplifier

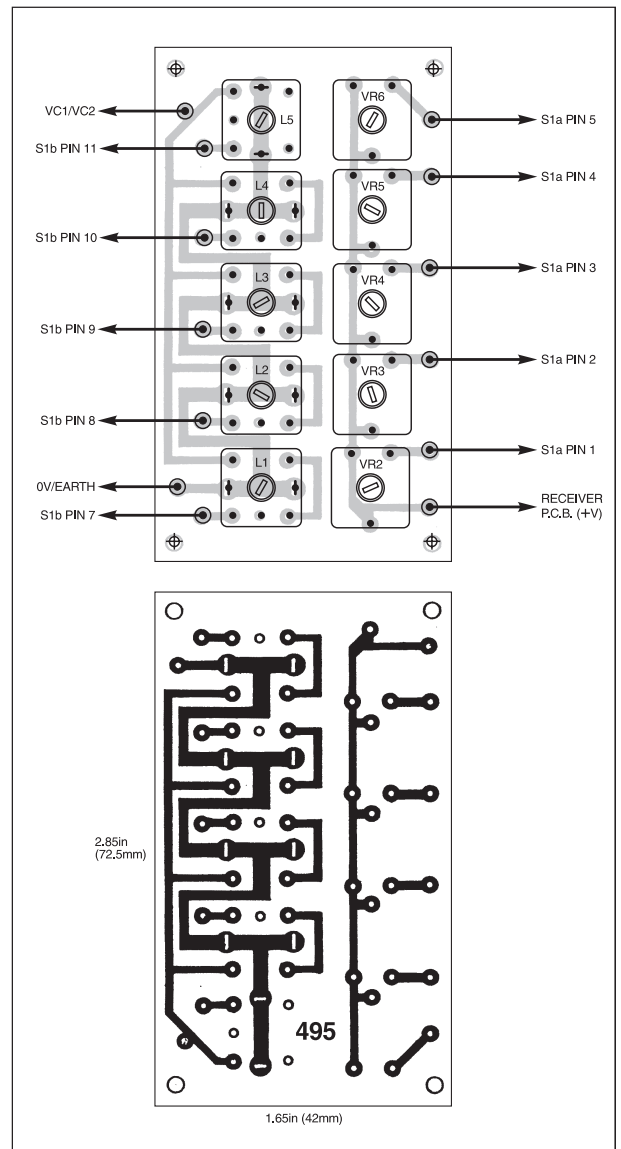

Fig.4. Printed circuit board component layout wiring details and full-sized foil master for the Coil Pack

Follow these items with the resistors and r.f. chokes, then the capacitors, smallest first, and, finally, the transistors and diode. Germanium diodes are vulnerable to damage by excessive heat during soldering. It is good practice to leave a sufficient lead length on these devices to allow a miniature crocodile clip to be attached to act as a heatshunt whilst soldering in position.

Make sure the Toko coils are correctly placed on the coil pack board before soldering them in position: they are difficult to remove. Straining the pins can result in open circuit coils.

Remember to insert a wire link if r.f. choke RFC2 is not fitted, and to provide a decoupling resistor for the Tuner if it is used with a different amplifier and connected to a shared power supply.

Fig.7(right). Amplifier printed circuit board component layout and wiring to off-board components. Note that a plastic bodied insulated stereo jack socket must be used for the headphones

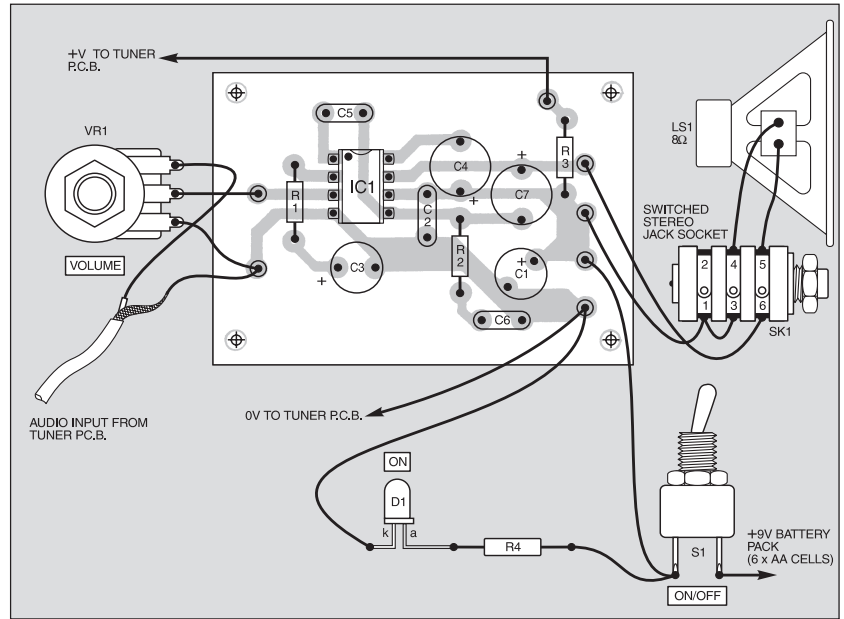
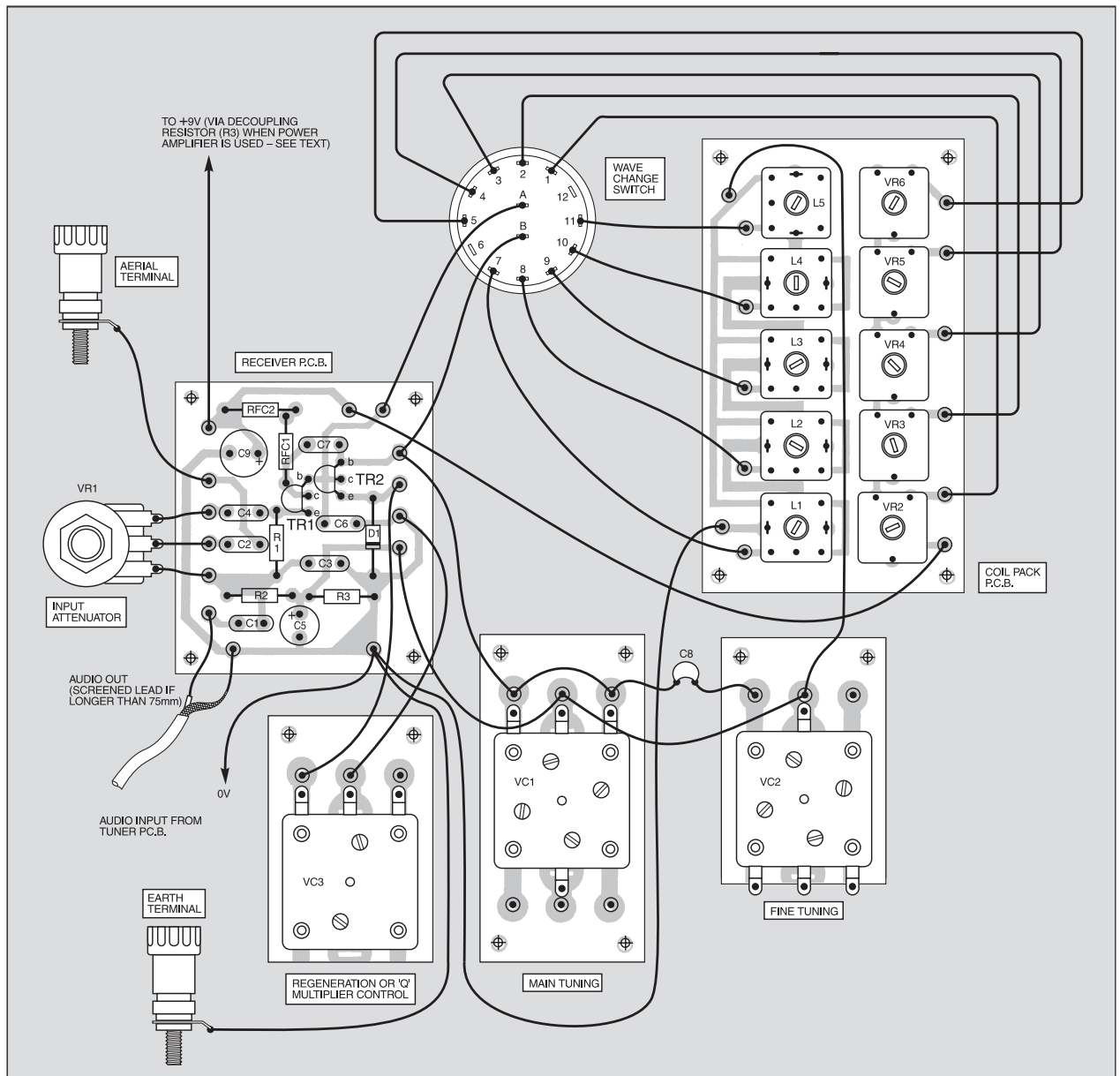

Fig.5(below). Interwiring to the wavechange switch and variable capacitor p.c.b.s



Variable Capacitors

Miniature polythene dielectric variable capacitors (otherwise known as polyvaricons) are used for tuning and the control of regeneration. Inexpensive and widely available, they can contain up to four gangs (separate capacitors) which can be combined to form different tuning swings.

The capacitors which tune the Receiver have two a.m. and two f.m. gangs. The bandset, or coarse, tuning capacitor VC1 is formed by wiring the two a.m. gangs in parallel to produce a swing of 10pF to 260pF. Some polyvaricons have a.m. gangs with a swing of around 300pF, in which case only one should be connected into circuit. These capacitors have a deeper case: around 20mm (3/4in.) instead of 12mm (1/2in.).

One of the 25pF f.m. gangs is used as the bandspread or Fine tuning capacitor VC2. It is connected across the bandset capacitor via series capacitor C8 (see Fig.5) which reduces its swing to produce a slower tuning rate.

The variable capacitor (VC3) used to control regeneration requires a swing of around 5pF to 100pF. An a.m.-only tuning capacitor is ideal for this purpose. These usually combine a 60pF oscillator stage tuner (marked O) with a 140pF aerial section (marked A on its case). Try the smaller of the two capacitors first, and if this doesn't have a big enough swing to make the set regenerate at all settings of the tuning capacitor, use the 140pF section. Clockwise rotation reduces the value of these capacitors. The Regeneration (Q-Multiplier) control is, therefore, advanced by turning the control knob anti-clockwise.

Moving vanes of variable capacitors are always connected to the "earthy" side of the circuit. Fixed vanes go to the "hot" or signal side. The connections shown in Fig.8 are typical of most components of this kind, but they do vary, and retailers will usually supply details.

The printed circuit board illustrated in

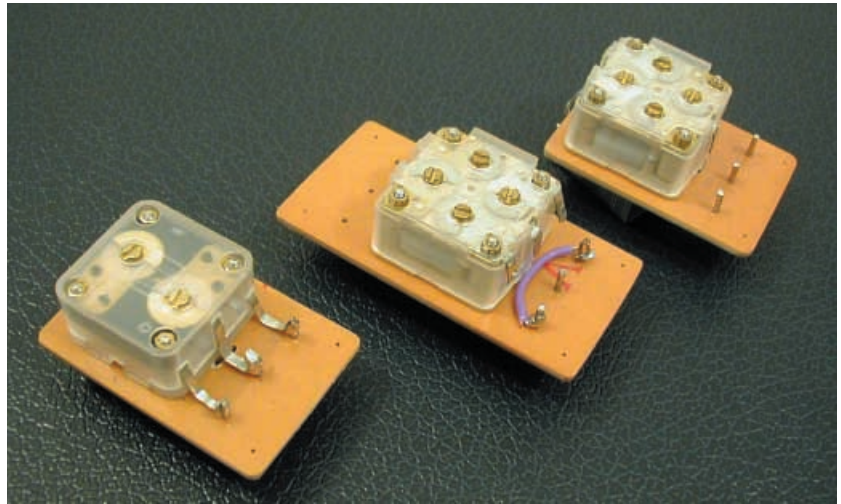

Miniature polythene dielectric (polyvaricon) variable capacitors mounted on p.c.b.s to aid wiring and ease mounting in the case. Note the two cut-down boards

Fig.8 will accommodate most screw or solder-tag fixed polyvaricons. It is useful for mounting these components behind the front panel, particularly when a slow-motion drive is provided or when the capacitor spindles have to be insulated. Any fixing screws driven into the variable capacitor's front plate *must be short* or they will protrude into the case and damage the vanes.

Extenders are required for the very

stubby spindles of these capacitors. With this design, the tuning capacitor moving vanes (connected to the spindle) are at a small positive potential, and they *must be insulated from any metal case*. Insulated spindle extenders are, therefore, to be preferred. As an alternative, a 6mm diameter nylon stand off, secured to the capacitor spindle with a 2mm metric bolt, will also serve if these parts are to hand or can be sourced.

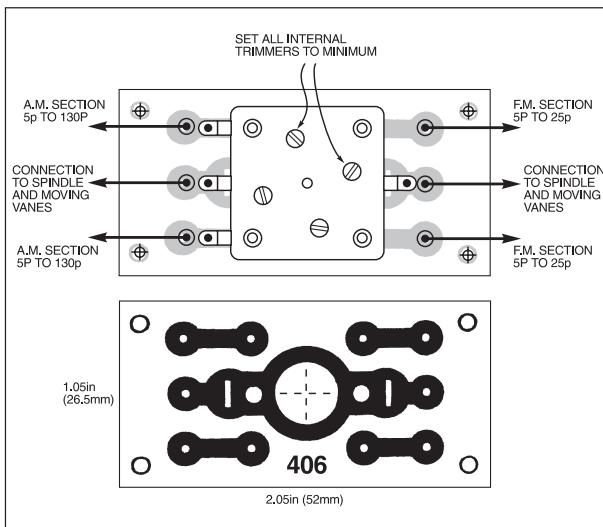
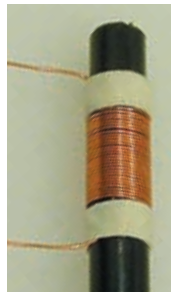

Fig.8. Typical connections and capacitor values for most 4-gang a.m./f.m. polyvaricons. The Fine Tune and Regeneration capacitors p.c.b.s have to be cut down to fit inside the case – see Fig.5. This p.c.b. will accept most screw or solder-tag fixed polyvaricons

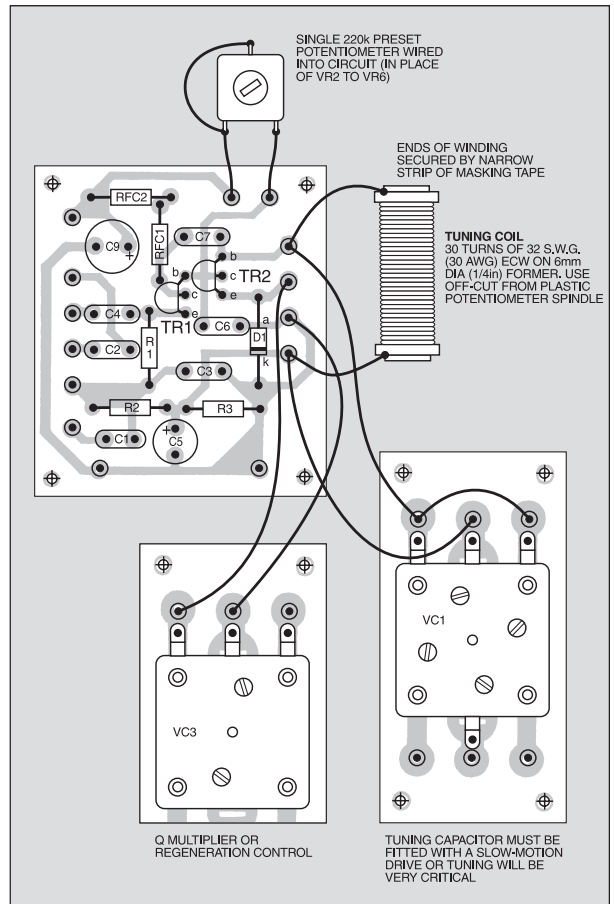
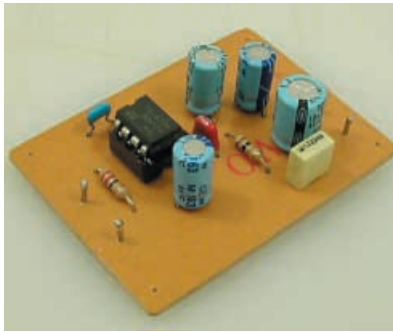

Fig.9. Simplified tuning arrangement using a hand-wound coil. Using this homemade coil will give a coverage of 6MHz to 16MHz



Components mounted on the Audio Amplifier p.c.b.

Headphones.

A headphone socket is an essential feature on any shortwave receiver. It should be of the switched kind to isolate the speaker when the phones are inserted. Most earphones are now of the stereo variety, and a stereo socket should be fitted and connected so that both earpieces are wired in parallel.

Testing

Commence testing by first checking the printed circuit boards for poor soldered joints and bridged tracks, then check the placement of components and the orientation of electrolytic capacitors, diode, transistors and integrated circuit.

It is a good idea to test the Receiver before mounting the various parts in a case, and the p.c.b.s can be temporarily wired up on the bench to facilitate this. Make the connections to the coil pack with crocodile clips on short leads, or adopt the simple single-coil arrangement depicted in Fig.9, for the test. Use short (no longer than 75mm or 3in.) leads to connect potentiometers and capacitors to the boards. You must use a screened lead to connect the Tuner p.c.b. to the Amplifier p.c.b.

Attach two to three metres (six to ten feet) of flex to act as an aerial, and set the r.f. potentiometer VR1 for maximum input. Set the regeneration preset potentiometers, VR2 to VR6, to the mid-way position, and turn the regeneration capacitor, VC3, fully clockwise (to minimum). Set all the variable capacitor's internal trimmers to minimum (vanes unmeshed: they can be viewed through the back of the capacitor's translucent case).

Connect a fresh 9V battery pack. Current drain of the tuner should be approximately 0.6mA (600 μ A), and the drain of the amplifier around 6mA under no-signal conditions.

Tuning-In

Advance the Regeneration control, VC3, until a faint hiss is heard in the loudspeaker. Rotating the Tuning capacitor, VC1, should now bring in a number of stations. Check all of the ranges on the coil pack, and adjust presets VR2 to VR6 until the regeneration control, VC3, operates smoothly at all settings of the tuning capacitor VC1. Best results will be obtained with the presets (wired as variable resistors) set at as high a resistance as possible (clockwise rotation). Guidance on operating the receiver is given later, and this may prove helpful during the testing process.



Layout of components and lettering of components mounted behind the top of the Receiver case. This arrangement allows room for a slow-motion drive for a front panel dial

Little and Large

Readers will have their own ideas about mounting the receiver in a case, and much will depend on whether a multiband or a single-band version has been constructed.

Single-band operation and the connection of a crystal earpiece to the Tuner board (the volume control can be omitted) opens up the possibility of a very small receiver. With a current drain of around 600 μ A, a PP3 battery should power the set for many hours.

When small size is not important, considerable advantage can be gained by fitting a larger speaker (at least 100mm or 4in. diameter) to make more efficient use of the power delivered by the Audio Power Amplifier.

Casing Up

The version of the Spontaflex Receiver described here is housed in a standard aluminium box, measuring 154mm \times 104mm \times 52mm (6in. \times 4in. \times 2in.), and the various photographs show the general arrangement of the components.

Stand-offs are used to mount the printed circuit boards and variable capacitors behind the front panel. Remember that the tuning capacitor spindles *must not* connect to the 0V rail, and the nylon extenders insulate them from the metal front panel.

In order to make room for a Tuning dial, the Aerial and Earth terminals, R.F. Input Attenuator potentiometer (VR1), Wavechange switch, On/Off switch and On indicator l.e.d. are mounted at the top of the case. An epicyclic slow-motion drive is fitted to the main tuning (band-set) capacitor, VC1.

With a layout as compact as this, it is recommended that colour-coded leads be soldered to the wavechange switch and the other components located at the top of the case before the printed circuit boards are mounted in position.

The loudspeaker, headphone socket, and volume control are located behind the front panel. A pattern of holes, 3mm (1/8in.) diameter, are drilled in the front panel to form a speaker grille, and the speaker glued in position behind them with cyanoacrylate adhesive (Superglue).

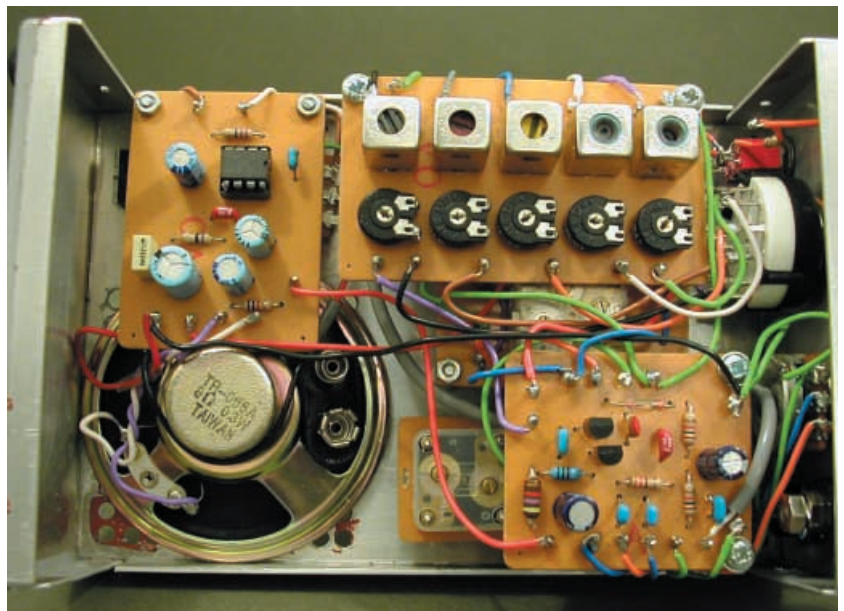

General layout of components and printed circuit boards inside the aluminium case. Note that the base of the case becomes the receiver's front panel and one end panel the top

Aluminium primer and car spray paint are used to finish the case, and the dials are marked out on white card and annotated with rub-down lettering. Acrylic sheet, the kind of 2mm thick material used for DIY double glazing, protects the card.

The prototype dials are reproduced, half-size, in Fig.10. Note the anti-clockwise rotation of the Q-multiplier or Regeneration control (VC3). A pointer for the tuning dial is cut from scrap acrylic sheet, and its scribed hairline filled with black ink (see photographs).

Power Supply

A pack of six AA cells represents an economical way of powering the Receiver. They are mounted in holders Superglued to the back and side of the case, and have to be carefully positioned to fit into the available space. The photographs show the general arrangement.

A PP3 battery is completely unsuitable for powering a receiver containing an amplifier of this kind. Its life would be short and its rising internal resistance would cause instability.

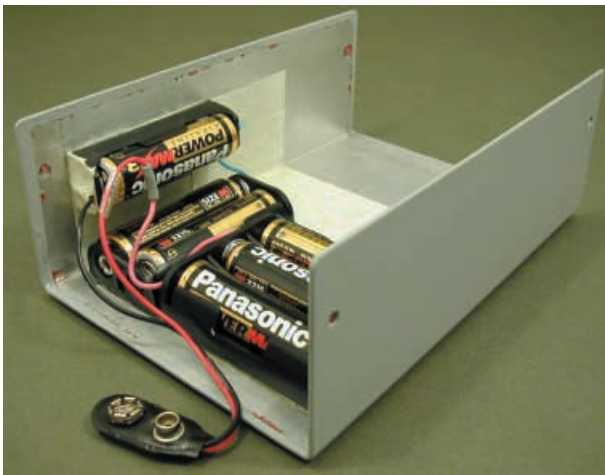

The Battery holders glued to the "top" and one side-wall of the case cover

Completed Receiver showing the p.c.b.s mounted on stand-off pillars

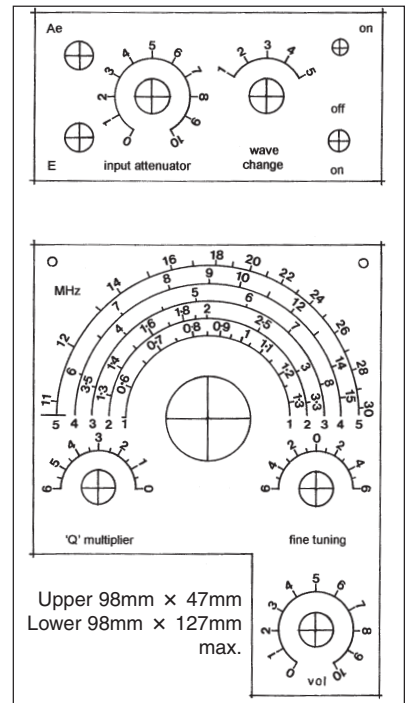
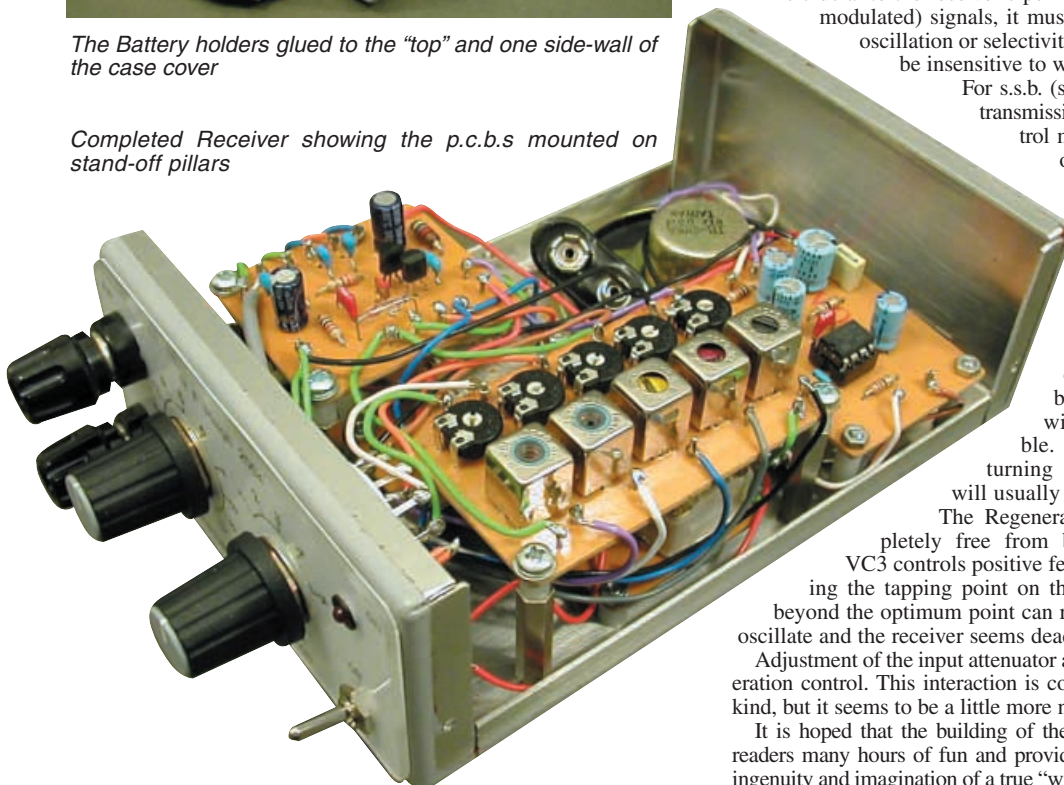

Fig.10 (above right). Top and front panel control dials reproduced half size. The completed Receiver is shown top left

Operations

Short aerials work best with this Receiver, certainly no more than six metres (twenty feet), and a length of wire stretched across the room is usually more than sufficient. An Earth connection will eliminate hand-capacity effects and improve reception on the lower frequencies. A lead clipped to the central heating pipework is likely to be satisfactory.

Turn the Input Attenuator down and use the Volume control to maintain the desired sound output. Even when very short aerials are fitted, strong signals can sometimes overload this receiver.

Regeneration

The correct setting of the Regeneration (Q-Multiplier) control is crucial to the receiver's performance. For a.m. (amplitude modulated) signals, it must be kept on the threshold of oscillation or selectivity will be poor and the set will be insensitive to weak signals.

For s.s.b. (single side band), the mode of transmission used by amateurs, the control must be advanced until the set oscillates. This local, signal frequency, oscillation replaces the carrier suppressed at the transmitter and the diode detector is able to recover the audio modulation in the usual way.

Tuning must be very precise when s.s.b. signals are being received, or the speech will be garbled and unintelligible. If a signal refuses to clarify, turning down the Input Attenuator will usually effect a cure.

The Regeneration control (VC3) is completely free from backlash. Variable capacitor VC3 controls positive feedback by electrically adjusting the tapping point on the tuning coil. Advancing it beyond the optimum point can result in the circuit ceasing to oscillate and the receiver seems dead.

Adjustment of the input attenuator affects the setting of the regeneration control. This interaction is common to all receivers of this kind, but it seems to be a little more noticeable with this circuit.

It is hoped that the building of the *Spontaflex* receiver will give readers many hours of fun and provide just a small insight into the ingenuity and imagination of a true "wireless experimenter". □