

Ingenuity Unlimited

Our regular round-up of readers' own circuits

WIN A PICO PC-BASED OSCILLOSCOPE WORTH £799

- 200MHz Analogue Bandwidth Dual Channel Storage Oscilloscope
- Spectrum Analyser
- Frequency Meter
- Multimeter
- USB Interface.

If you have a novel circuit idea which would be of use to other readers then a Pico Technology PC-based oscilloscope could be yours.

After every 20 published IU circuits, Pico Technology will be awarding a PicoScope 3206 digital storage oscilloscope for the best IU submission. In addition a PicoScope 2105 Handheld Scope worth £199 will be presented to the runner up.

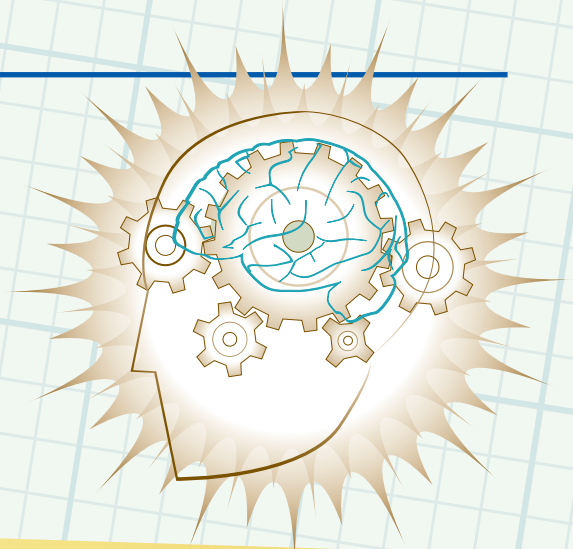
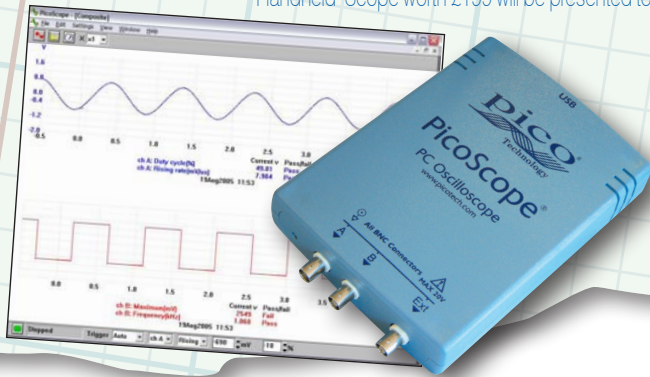

We pay between £10 and £50 for all material published, depending on length and technical merit. We're looking for novel applications and circuit designs, not simply mechanical, electrical or software ideas. Ideas must be the reader's own work and **must not have been published or submitted for publication elsewhere.**

The circuits shown have NOT been proven by us. **Ingenuity Unlimited** is open to ALL abilities, but items for consideration in this column should be typed or word-processed, with a brief circuit description (between 100 and 500 words maximum) and include a full circuit diagram showing all component values. **Please draw all circuit schematics as clearly as possible.** Send your circuit ideas to: Ingenuity Unlimited, Wimborne Publishing Ltd., 113 Lynwood Drive, Merley, Wimborne, Dorset BH21 1UU. Email: editorial@epemag.wimborne.co.uk.

Your ideas could earn you some cash and a prize!

Experimenter's All-Band Radio – *radio without tears*

MANY years ago, the author designed an *All-Band Radio* which was featured as a constructional project in *EPE*. The design did not end there, however. The author continued to develop it and tweak it over the years, until it reached the form shown here.

The circuit diagram shown in Fig.1 might be described as an 'AM radio without tears'. It is a robust little radio that should work no matter what – with virtually any tuned circuit, any aerial (or none at all), and without the need for an earth wire. It has good sensitivity, good selectivity, and modest power into a 1W RMS loudspeaker – or good power into headphones. While sound quality is modest, the circuit may be unmatched for economy and simplicity.

At the core of the circuit (Fig.1) is IC1, which serves both as receiver and preamplifier. Being a 4000-series CMOS IC, it is capable of operating (in theory) up to 5MHz, and in practice well above this. Therefore, the radio has a wide coverage – being capable of receiving long waves (LW) through to the short wave (SW) 41-metre band. Since this is a regenerative receiver, it will also (potentially) pick up single-sideband transmissions (SSB).

This type of radio is regenerative – a personal favourite of the author. Simply described, instead of having volume and tuning dials only, it has volume, tuning, and

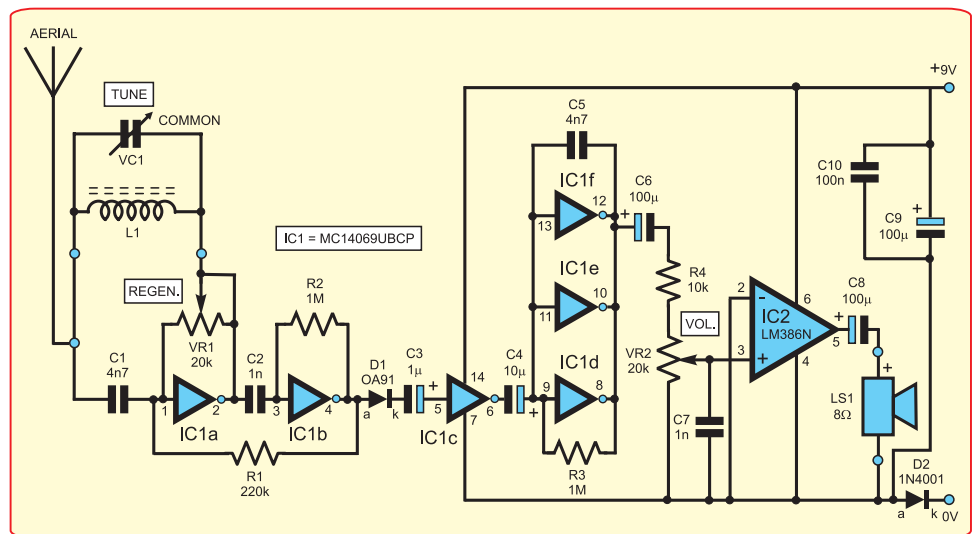

Fig.1. Experimenter's All-Band Radio

regeneration dials, which leads to a fascinating balancing act in practice.

Circuit details

At the heart of the circuit lies an unbuffered hex inverter, IC1. Although this is classed as a digital device, it may in some situations serve as an analogue amplifier up to several megahertz. The circuit has been specifically designed around the Motorola MC14069UBCP inverter IC, and this is the device which should be

used for best results. Equivalents might disappoint.

When a station is tuned in, VC1 and L1 resonate at the tuned frequency. In other words, they present a minuscule alternating voltage to the input of IC1a through DC-blocking capacitor C1. Therefore, any activity in the tuned circuit unsettles both the input and the output of IC1a, sending ripples down the chain IC1a to IC1f, which are amplified and demodulated as they go.

The input of a 4069 inverter gate is typically biased at around half the supply

voltage, and this bias may be stabilised by adding a feedback resistor such as R2, so that the output and input equalise. The greater the value of the feedback resistor, the more sensitive the input will be.

To bring about regeneration, the tuned circuit is inserted in the feedback path of IC1a. The higher the value of VR1, the greater IC1a's potential for 'being unsettled', and the greater the regeneration as the amplified signal is passed back to input pin 1 through the tuned circuit via output pin 2. Further regeneration is provided through resistor R1, so that regeneration in this circuit occurs through two paths simultaneously, namely through the tuned circuit itself, and through R1.

The purpose of regeneration is to reinforce the RF signal through positive feedback. Not only does this amplify the signal, but it also sharpens it a great deal.

Inveterate gate IC1b serves to amplify the radio frequency (RF) signal, which is fed back to IC1a through R1 to provide the additional regeneration. Resistor R2 stabilises IC1b and manages its gain. Diode D1 provides demodulation (that is, it extracts the audio signal), while capacitor C3 couples IC1b to IC1c.

A common disadvantage of using a simple diode for demodulation is that this may kill weaker signals through its voltage drop. Therefore, before demodulation is applied to this circuit, RF amplifier stage IC1b is added.

IC1c, which is wired as a simple buffer, further amplifies the signal. By omitting any feedback components here, this prevents any destabilisation of the radio circuit through feedback from the 'power' section. IC1d to IC1f are paralleled to provide maximum current for the amplifier IC. Capacitor C5 serves as a low-pass filter, and improves the tone of the radio. In fact, when using headphones, the tone is excellent and 'full-bodied'.

Finally, amplification is provided through a well known amplifier IC, the LM386N. Amplifier volume is controlled through rotary potentiometer VR2.

The radio draws 20mA to 30mA current, which should see it through about two days and nights continuous use off a 9V AA battery pack. Note that the radio will take a few seconds to come to life after switch-on. This should be heard by a hiss appearing in the loudspeaker.

Tuned circuit and aerial

The most commonly available AM tuners (variable capacitors), typically have two separate sections or gangs (that is, two variable capacitors with one common terminal). A tuned circuit for the medium waves could use such a tuner with its two separate sections wired in parallel.

Either a ready-made medium wave coil may be used for L1, or this may be wound with 80 to 100 turns of approx. 30swg (0.315mm) enamelled copper wire, close-wound on a 10mm diameter ferrite rod.

Both VC1 and L1 may be pulled out of an old radio set. Don't hesitate to wire up different coils and variable capacitors (AM tuners) to see what the circuit does with them. Also, try experimenting with different aerials, which could greatly increase the range of the radio. It should be possible to pick up many distant stations at night (but not during the day – for example, *Deutsche Welle*, or *Radio China* – by winding a length of enamelled copper wire a few times around a room. Also, burglar bars or even a tree may serve reasonably well as an aerial.

In order to access higher frequencies, thicker gauges of wire should be used for coil L1, with fewer turns, spaced out more widely on the ferrite rod, or even being air spaced. For example, the 41-metre short-wave band may be accessed with an air spaced coil wound on a 25mm diameter former, comprising 10 turns of 24swg (0.56mm) enamelled copper wire. This is then stretched out to 25mm from end to end.

When using the radio, regeneration needs to be held as high as possible without introducing excessive feedback to the circuit. Excessive feedback is manifested either through 'juddering' or 'shrieks' in the loudspeaker or headphones – or by the circuit going completely 'dead' (this will not harm the circuit).

Generally speaking, Regeneration control VR1 will need to be adjusted to about half its value. Volume control VR2 will need to be turned up as high as it will go without excessive distortion.

Much depends on the length of the aerial, and on signal strength. On the higher shortwave bands in particular, regeneration will need to be turned up full, and the values of VR1 and R1 might even be altered. The value of resistor R1 may be reduced (eg, to 100k for more radical regeneration), or R1 could be replaced with a 500kΩ preset potentiometer for greater flexibility in experimenting.

To put it simply, a regenerative radio requires a careful balance of all the controls for best reception, and a good deal of experimentation may be required to get the best out of it.

Happy listening!

Thomas Scarborough,
Cape Town, South Africa

pico
Technology

AFFORDABLE EXPERTISE

THE PC OSCILLOSCOPE RANGE FROM
PICO TECHNOLOGY

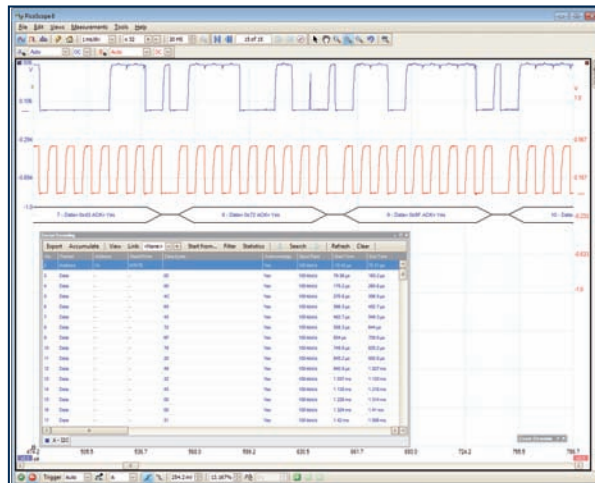

BANDWIDTH
20 MHz to 12 GHz



SAMPLING RATES
50 MS/s to 5 GS/s



MEMORY
8 kS to 1 GS

RESOLUTION
8 to 16 bits

PRICES
£125 to £6995

Latest Software Updates: I²C & CAN bus decoding,
mask limit testing, advanced triggers,
digital low pass filtering, rapid triggering

www.picoauto.com/scope2015