

All-Band Radio

Thomas Scarborough

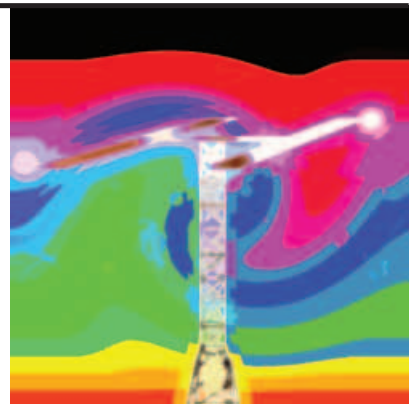

A no frills, low budget, easy-build, sensitive radio with excellent reception

ONE might call this a “dog” of a radio. It doesn't pretend to any finesse. It doesn't have high fidelity sound. However, it has good coverage, and good sensitivity. Moreover, it is a robust design that, unlike many others, does not depend on daintily wound coils, obscure parts, or a carefully constructed antenna.

Built in Cape Town, South Africa, the prototype All-Band Radio brought in a good many stations from all around the world – loud and clear. This included the BBC, the Voice of America, Radio China, Radio Iran, the Deutsche Welle, and many more besides. Well into the night, it even picked up local Australian stations on the medium waves.

Regeneration

Despite its simplicity, this regenerative set has sharper tuning and greater sensitivity than many other tuned radio frequency (t.r.f.) sets. On the medium waves, it works well even without an external antenna or earth, although an aerial may be attached to very good effect. Also, while its volume is modest, it is strong enough to serve as a bedside radio, or in a small workshop.

A regenerative radio is interesting to work with. It might be compared with a manual car as opposed to an automatic. In addition to the customary Volume control and Tuning dial, it has a third Regeneration dial to control regeneration. Regeneration “regenerates” the received signal, much as a child on a swing increases the energy of the swing with modest kicks of its legs. This type of radio was invented by Major Armstrong in 1912, bringing about a vast improvement in radio receivers at that time.

At first it was thought that the set's maximum frequency would lie around 5MHz – that is, the shortwave 60 metre band. In practice, however, it picked up radio stations above 7MHz. Therefore it has the potential to tune in the following bands:

<i>Long Wave</i>	
<i>Medium Wave</i>	
<i>Marine Band</i>	<i>120 metres</i>
	<i>90 metres</i>
	<i>75 metres</i>
	<i>60 metres</i>
	<i>49 metres</i>
<i>Short Wave</i>	<i>41 metres</i>

Mini Radio

At the heart of this radio circuit is the 4069UB (unbuffered) hex inverter i.c. which is able to provide a powerful signal into a crystal earpiece. Therefore, the circuit obviously has the potential for miniaturisation. With this in mind, the author further designed a p.c.b. layout for a miniature radio (see Fig.4), and it remains to the ingenuity of the constructor to fit this into a suitably small plastic case.

Circuit Description

As mentioned above, the heart of the circuit is represented by inverting buffer IC1a (see Fig.1). Although this is classed as a digital device, it may in some situations serve as an analogue amplifier up to several megahertz, albeit without the same quality of reproduction as a dedicated analogue amplifier i.c.

The full circuit diagram for the All-Band Radio is shown in Fig.1. When a station is tuned in, variable capacitor VC1 and coil L1 resonate at the tuned frequency. In other words, they present a minuscule alternating voltage to the input of IC1a through d.c. blocking capacitor C1. Therefore any activity in the tuned circuit unsettles both the input and the output of IC1a, sending ripples down the chain IC1a to IC1f, which are amplified and demodulated as they go.

To bring about regeneration, the tuned circuit is inserted in the feedback path of IC1a, while resistor R1 and potentiometer VR1 serve to balance IC1a at roughly half the supply voltage. The higher the value of VR1, the greater IC1a's potential for being unsettled, and the greater the regeneration as the amplified signal at input pin 1 is passed back through the tuned circuit via output pin 2.

The purpose of regeneration is to reinforce the r.f. signal through positive feedback. Not only does this make the signal louder, but it also sharpens it a great deal. As a matter of interest, Fig.2 shows how this circuit might have looked if a more standard tuned radio frequency (t.r.f.) configuration had been used, and it would be instructive to try this out. The result is much vaguer tuning, and reduced volume.

When using the radio, regeneration needs to be held as high as possible without introducing instability to the circuit.



Front panel controls for the full version of the All-Band Radio

Such instability is manifested either through “shrieks” or “juddering” in the loudspeaker or earpiece. Generally speaking, however, it will be possible most of the time to turn up regeneration to the maximum without this occurring. Regeneration will be needed particularly if a longer aerial is employed.

It is possible, with a small modification to the circuit, to introduce the most radical regeneration, and therefore very sharp tuning (that is, high selectivity). This is done by wiring a 10 megohm resistor between IC1a pin 1 and IC1b pin 4. However, while this would take the All-Band Radio to its full potential, it would also make it tricky to use in practice. In this case, R1 and VR1 would best need to be tweaked for greater ease of use.

Inverter IC1b serves to amplify the radio frequency (r.f.) signal, while diode D1 provides demodulation (that is, it extracts the audio signal). A common disadvantage of using a simple diode for demodulation is that this may kill weaker signals through its voltage drop; hence the choice of a germanium type. Therefore before demodulation is applied to this circuit, r.f. amplifier stage IC1b is added. Diode D1 thus demodulates a far stronger r.f. signal, and far fewer stations are lost in the process.

Tuning-In

One of the particular advantages of this design is that virtually any tuned circuit may be tried for VC1 and L1, on condition that this is tuned to less than about 8MHz. So, for instance, various coils and a.m. tuners (tuning capacitors) may be pulled out of junked radio circuits, and the majority would be likely to work, possibly with interesting results.

The most commonly available a.m. tuning capacitors typically have two separate sections (that is, two variable capacitors with one common terminal – ask your component shop to identify the terminal pins). A tuned circuit for the medium waves could use such a tuner with its two separate sections wired in parallel, together with L1 which would be about eighty to a hundred turns of 30s.w.g. (0.15mm)

enamelled copper wire close-wound on a 10mm diameter ferrite rod. This does not, however, represent an ideal Q for the tuned circuit – more later.

In order to access higher frequencies, thicker gauges of wire would be used, with fewer turns, spaced out more widely on the ferrite rod, or even being air-spaced. The author accessed the 41 metre shortwave band with an air-spaced coil which was wound on a 25mm diameter former, with 10 turns of 24s.w.g. (0.56mm) enamelled copper wire. This was then stretched out to 25mm from end to end.

Don't hesitate to wire up different coils and a.m. tuning capacitors to see what the circuit does with them. Also, try experimenting with different aerials, which could greatly increase the range of the radio. The author picked up many distant stations by winding a length of enamelled copper wire a few times round his work room. Even a tree may serve well as an aerial. In the case of the tree, the connection is made by sticking a pin through the bark.

As a matter of interest, Raymond Haigh's, series *Practical Radio Circuits* (EPE Sept '03 P646) gives some examples of coils which could be tried to bring in different frequencies. Note also that since

inductance drops when inductors are wired in parallel, the frequency of the radio could be raised simply by wiring coils in parallel with the existing coil. Although this is not ideal, it is an easy way to experiment.

Going Minature

If the miniature version of the Radio should be built, coil L1 may be compressed by using a short stub of 10mm diameter ferrite rod, pile-winding eighty to a hundred turns of 30s.w.g. (0.315mm) enamelled copper wire on the stub. The a.m. tuning capacitor may further be miniaturised by wiring a trimmer capacitor, in series with a small fixed value capacitor, in its place. The fixed value would need to be chosen experimentally so as to pick up one's chosen radio station or stations, since the tuning range would be reduced in this case.

Theoretically, the tuner may be no more than two metal plates with a dielectric (e.g. a sheet of plastic). Many years ago, the author bought the Soviet Astrad Orion, which was possibly the smallest radio ever to have become widely available. Out of curiosity, it was opened up to examine the tuning capacitor, and a single metal plate fell out. This, together with a plate on the front of the case, formed the tuning capacitor.

Q-Factor

In order to experiment intelligently with the All-Band Radio, one should best have some understanding of the Q -factor. The radio as shown (Fig.1) has been designed for a relatively high Q , although it does not depend on this to work reasonably well.

A common definition of Q is “the ratio of the reactance of an inductor (in this case coil L1) to its effective series resistance at a given frequency”. However, a simple way of putting this is that Q represents the “power” with which the tuned circuit resonates at a given frequency. As in many situations, it is one thing to get something to work – it is another to get it to work efficiently.

The formulae for calculating the ideal Q are relatively complex, but two factors are especially important for obtaining a good Q .

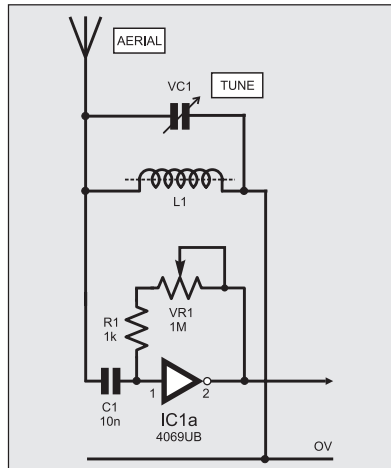

Fig.2. Standard t.r.f. configuration

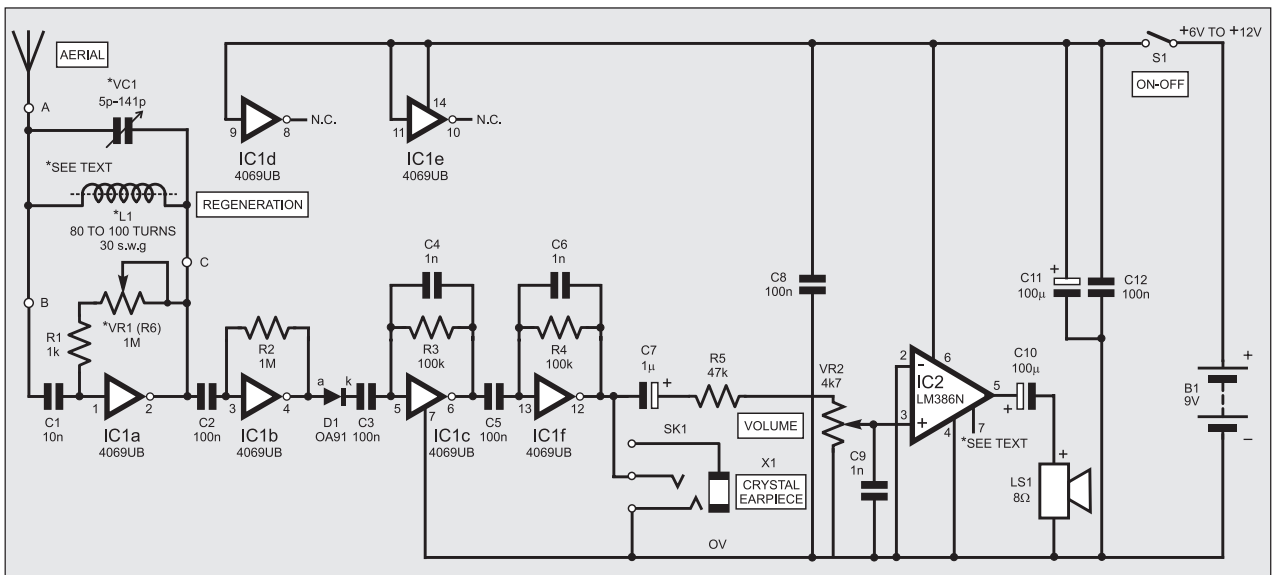
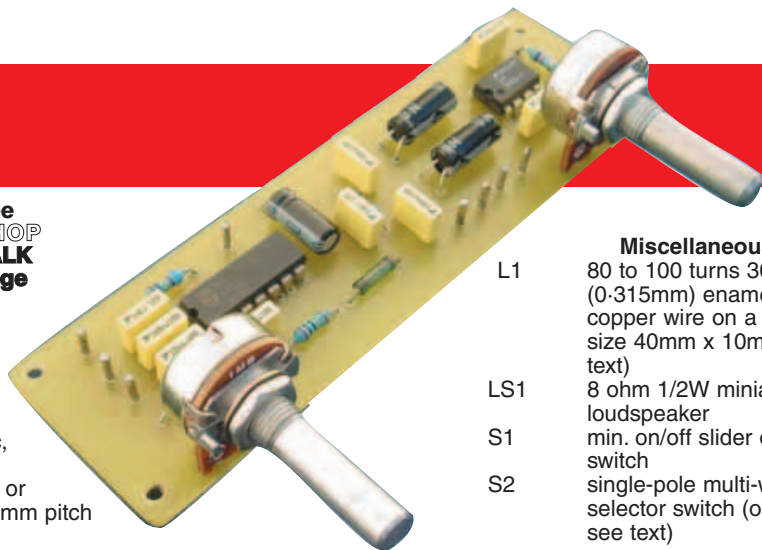

Fig.1. Complete circuit diagram for the “full version” of the All-Band Radio

COMPONENTS



Resistors

R1	1k
R2	1M
R3,R4	100k (2 off)
R5	47k
R6	1M (see text)

All 0.25W 5% carbon film

Potentiometers

VR1	1M min. carbon track or conductive plastic, 5mm pitch
VR2	4k7 min. carbon track or conductive plastic, 5mm pitch

Capacitors

C1	10n polyester or ceramic
C2,C3,C5,	
C8,C12	100n polyester or ceramic (5 off)
C4,C6,C9	1n polyester or ceramic (3 off)
C7	1 μ radial elect. 16V
C10,C11	100 μ radial elect. 16V (2 off)
VC1	126p, 141p a.m. variable, with trimmers (see text)

Semiconductors

D1	OA91 or similar germanium diode
IC1	4069UB (unbuffered) CMOS hex inverting buffer i.c.
IC2	LM386N-1 audio amplifier i.c.

See
SHOP
TALK
page

Miscellaneous

L1	80 to 100 turns 30s.w.g. (0.315mm) enamelled copper wire on a ferrite rod, size 40mm x 10mm (see text)
LS1	8 ohm 1/2W miniature loudspeaker
S1	min. on/off slider or toggle switch
S2	single-pole multi-way Band selector switch (optional – see text)
SK1	2.5mm or 3.5mm mono jack socket, chassis mounting (optional) crystal earpiece optional – see text)
X1	9V battery (PP3 type), with clips

Printed circuit boards available from the *EPE PCB Service*, codes 523(Full) and 524(Mini); case, size 130mm x 70mm x 40mm approx. (or to suit Mini version); 8-pin d.i.l. socket; 14-pin d.i.l. socket; plastic knob (3 off); aerial wire; screened microphone cable (about 30cm); cable ties; solder tag; solder pins; solder etc.

Approx. Cost
Guidance Only

£16

excl case and batts

The first is that fine wire should be used for coil L1, or more exactly that skin effect should be avoided – a complaint that applies to thicker wire gauges, and raises the effective (a.c.) resistance of the coil. Often, therefore, a coil is wound with several strands of fine wire twisted together but insulated from each other, being equivalent in their total cross-sectional area to the wires they replace.

A second factor is to maximise the influence of coil L1 on the tuned circuit, and to minimise capacitance and resistance. This is done by minimising the value of variable capacitor VC1, and by maximising the value of coil L1 – as well as minimising any resistance in the tuned circuit.

Described from a practical point of view, some tuned circuits will cause the All-Band Radio to pick up stations at full volume, while others will cause it to pick them up more quietly. Therefore if you should decide to recycle a tuned circuit from another radio, it might be worth taking it out of a full-sized radio set to obtain good *Q*, and to choose a case for the All-Band Radio that is able to accommodate this. This will ensure a reasonably strong sound input to the loudspeaker.

It is known that the *Q*-factor suffers especially when miniaturising the tuned circuit, and for this purpose, it is possible to increase the amplification of the All-Band Radio. Resistor R2 may be increased up to about 4M7, R3 may likewise be increased up to about 4M7, and R4 may be increased a little (say to 220k Ω).

Audio Circuit

Two preamplifier stages (IC1c and IC1d) follow after the r.f. section. Their gain is set through resistors R3 and R4. Each of these

stages filters out high frequencies (including radio frequencies) with the use of a small feedback capacitor (C4 and C6). A reduction of the values of these capacitors gives a “sharper” sound, arguably increasing the clarity of reception. However, this also increases hiss. The two spare inverter gates IC1d and IC1e (IC1 pins 9 and 11) are “tied high” to prevent any instability.

Note that because this circuit is based on a cheap CMOS 4000-series i.c. instead of dedicated radio and audio i.c.s, its sound quality suffers somewhat, in particular through the introduction of hiss. However, for everyday listening, the quality is quite adequate.

The two preamplifier stages are followed by a Volume control (VR2) and a low-pass filter (C9). A basic hazard of radio circuits is that the audio amplifier might be fed with radio frequencies (r.f.) that have slipped through the preceding stages, thus overloading the amplifier. The amplifier thus works too hard with signals that the listener is unable to hear. Therefore adequate filtering is important. Notice also the decoupling capacitors C8, C11, and C12, which are not used merely for “good practice”, but make a noticeable difference to sound quality.

Using the popular LM386 audio amplifier i.c., IC2 is capable of providing up to about 1/2W r.m.s. at 9V into an 8 ohm loudspeaker. If desired, its gain may be increased by wiring a capacitor between pins 1 and 8 of IC2, the value of which may be between about 100nF and 10 μ F. The capacitor’s positive terminal is wired to pin 1.

The usual Zobel network at the output is omitted for the sake of simplicity. The small measure of protection which a Zobel

network would afford IC2’s internal transistors ought not to be missed here, although constructors of a more nervous disposition might wish to wire a 10 Ω resistor and a 100nF capacitor in series from IC2 output pin 5 to the 0V line.

For the miniature version of the Radio, IC2 is completely omitted, leaving a powerful “crystal” set which feeds a crystal earpiece (X1), via jack socket SK1, wired from IC1f output pin 12 to 0V – or an inductive earpiece may be used if it is wired in series with a 1 μ F capacitor.

The All-Band Radio’s quiescent current consumption is relatively high. The miniature version of the radio draws about 30mA at 9V, while the fully built version with amplifier and speaker will consume upwards of 50mA, depending on the volume. This means that an alkaline PP3 type 9V battery might last ten or fifteen hours for the miniature version, and five or eight hours for the fully built version.

For regular use, therefore, a regulated mains-to-d.c. power supply (mains adaptor) might be considered. If there should be any hum as a result of using a power supply, a 10 μ F capacitor may be wired from IC2 pin 7 to 0V, and this is likely to improve matters significantly. Alternatively, a better quality supply might need to be used.

Construction – Full Version

Since this is a radio circuit, it is of prime importance that connections to off-board components should be made with screened microphone cable. The screen is always taken to 0V where this applies. The wires from L1 and the battery may be excepted on condition that these are kept as short as reasonable.

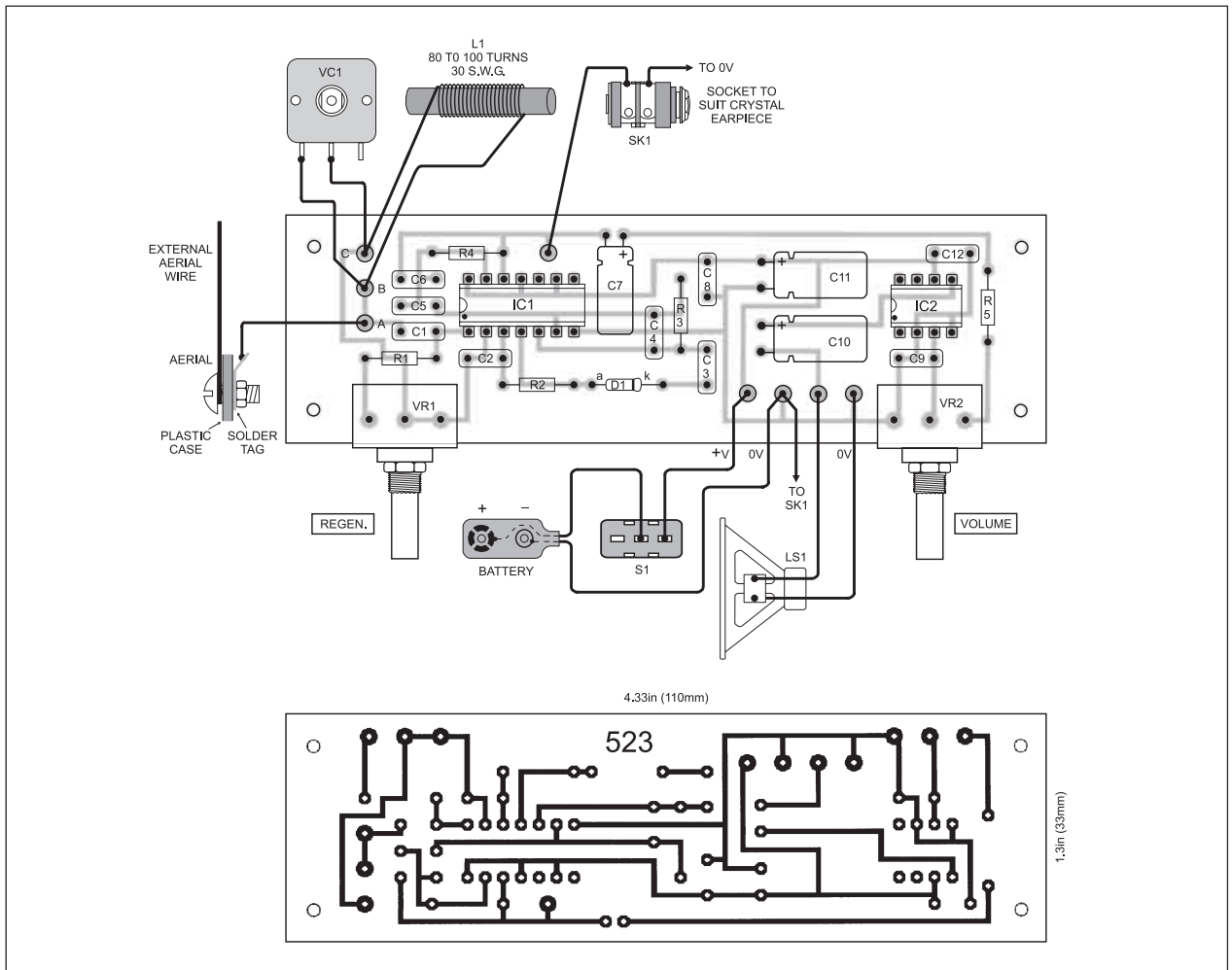

Fig.3. Printed circuit board component layout, full-size copper foil master and off-board wiring details for the full version of the All-Band Radio

The printed circuit board (p.c.b.) for the fully built version measures 110mm × 33mm, and the component layout, full-size copper foil master and wiring details are shown in Fig.3. This board is available from the *EPE PCB Service*, code 523 (Full).

Begin construction by soldering in position the eight solder pins, five resistors and twelve capacitors, taking note of the polarity of the electrolytics. Insert and solder potentiometers VR1 and VR2 on the p.c.b.

Lastly, solder the germanium diode D1 and the two i.c.s – observing anti-static precautions for both (ensure that your body has been discharged to earth). The author soldered the i.c.s directly to the p.c.b., for the reason that this is a sensitive radio circuit, however readers can, if they wish, use dual-in-line (d.i.l.) sockets.

Attach the loudspeaker LS1 and tuning capacitor VC1 to the p.c.b. with suitable lengths of microphone cable. Attach the battery clip and on-off switch S1 as shown. Solder the leads of coil L1 to the p.c.b., keeping these as short as possible.

Casing-Up

An ABS plastic case of approximately 130mm × 70mm × 40mm was used to house the prototype p.c.b. Drill three holes in the front (bottom) of the case for VR1, VR2 and VC1. Drill a series of “sound”

holes in the lid (rear) for the small loudspeaker and then attach it to the rear of the lid (or elsewhere, if a larger case is used). Make sure there is plenty of room between the rear of the speaker and the circuit board.

Prepare a hole in one side wall for the on-off switch S1. Drill a hole and bolt a solder tag to the other side wall of the case, taking a short length of wire from

the tag to the p.c.b. This is used later to attach an aerial if desired. The author held the battery and ferrite coil L1 in place inside the case with cable ties, see photograph below.

If desired, a number of different coils for L1 may be switched in and out of use, so as to access the different bands. For this purpose, a single-pole multi-way rotary switch would be used.

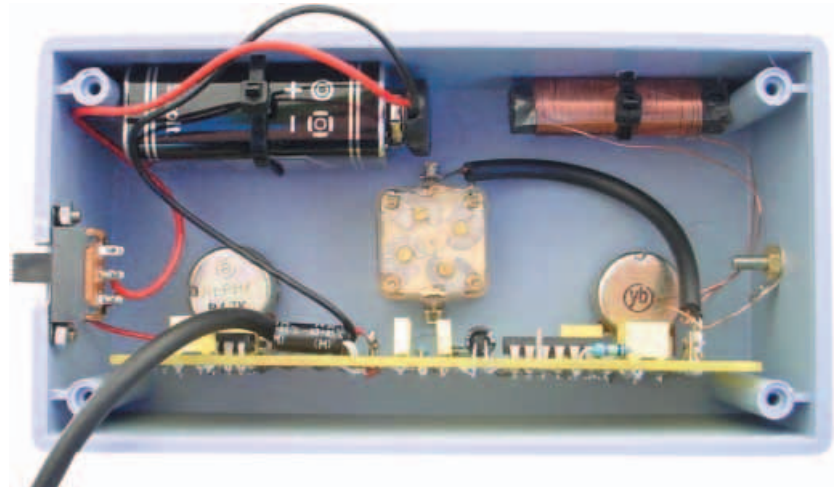

Internal component layout of the radio showing the battery and ferrite coil held in position with cable ties.

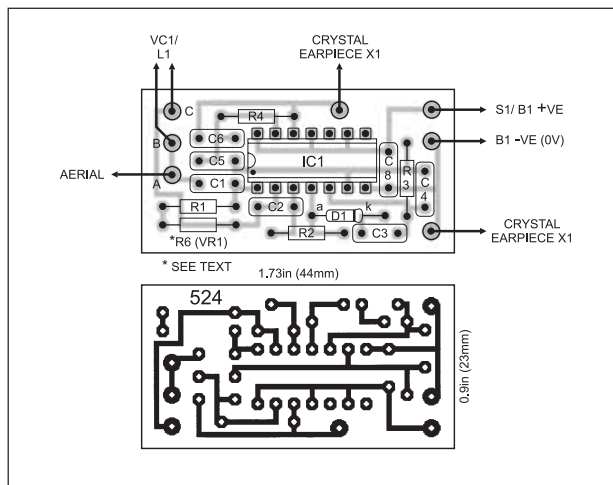

Completed Mini Radio circuit board

Fig.4. Mini version p.c.b. component layout, wiring and copper foil master

Construction – Mini Version

The p.c.b. component layout and full-size copper foil master for the miniature version of the Radio, which measures a mere 44mm × 23mm, is shown in Fig.4. This board is also available from the *EPE PCB Service*, code 524 (Mini).

The mini version has potentially the same performance as the fully built version, except that it uses an earpiece instead of a loudspeaker. A jack socket SK1 may be used for the earpiece X1, or it may be soldered directly to the p.c.b., with a dab of glue acting as a strain relief for X1's leads.

Commence construction by soldering in position the seven solder pins and five resistors. Note that Regen. control VR1 is replaced on this p.c.b. with a one megohm (1M Ω) fixed value resistor, to conserve space. A 1M Ω potentiometer may by all means be used instead. A 1M Ω fixed value resistor should not cause excessive regeneration unless a particularly generous length of aerial is used.

Next, insert and solder in position the seven capacitors, the germanium diode D1 and IC1, again observing anti-static precautions with the i.c. Coil L1 and tuning capacitor VC1 may be miniaturised as described earlier.

Finally, a suitable miniature slider or toggle type switch is wired up, together with a battery or batteries. Bear in mind that current consumption is relatively high, and some smaller batteries might only last

an hour or so. Any batteries from 6V to 12V may be used. A possible choice would be a standard small keyfob battery, the MN21 or A23.

Set-Up and Use

Begin the setting up procedure by turning the Regeneration control (VR1) fully clockwise. Turn up the Volume control (VR2) to about half. Switch on – then turn the tuning dial (VC1) until a station is tuned in.

On the medium waves in Europe or North America, there should be no shortage of stations even without an external aerial. However, in Southern Africa or Australia, stations may be relatively few and far between – perhaps just one or two until night falls and an aerial is attached. As with all medium and short wave sets, reception is very much improved at night, particularly as one approaches midnight.

If without an external aerial nothing at all is tuned in on the medium waves, try re-orientating coil L1 for better reception. Alternatively, L1 and tuning capacitor VC1 may not be covering the desired frequencies, and another coil might be required.

If, even with an aerial, nothing at all is tuned in, check that all components are correctly placed on the p.c.b., and that there are no solder bridges or dry solder joints. Since this is a sensitive radio circuit, it might be worth briefly melting each joint again with the soldering iron. Inadequate joints are seldom visible to the eye.

If there is excessive regeneration or instability in the form of “shrieks” or “judging”, first try turning down the volume (VR2). If this does not restore stability, reduce regeneration by slowly turning back VR1. Once stability returns, the volume may be turned up again. Regeneration needs to be kept as high as possible, so that tuning is as sharp as possible.



Once the All-Band Radio is working satisfactorily, different coils may be substituted for L1, or these may simply be wired in parallel with L1 as described earlier. Avoid attaching coils with crocodile clips, since such clips are bulky, and may lead to stray r.f. and capacitive effects that could kill reception completely. Rather use short leads which are wired directly to the p.c.b., or to solder tags close to the p.c.b.

Happy listening! □

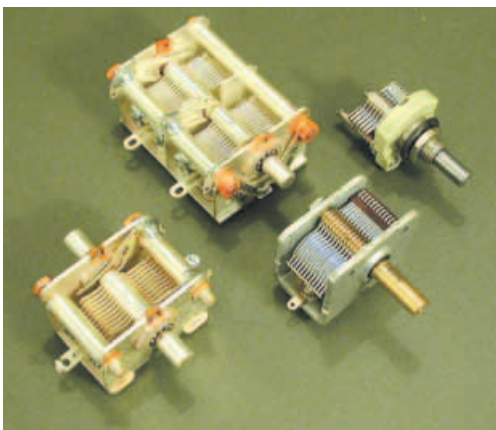

Group of air-spaced variable capacitors

