

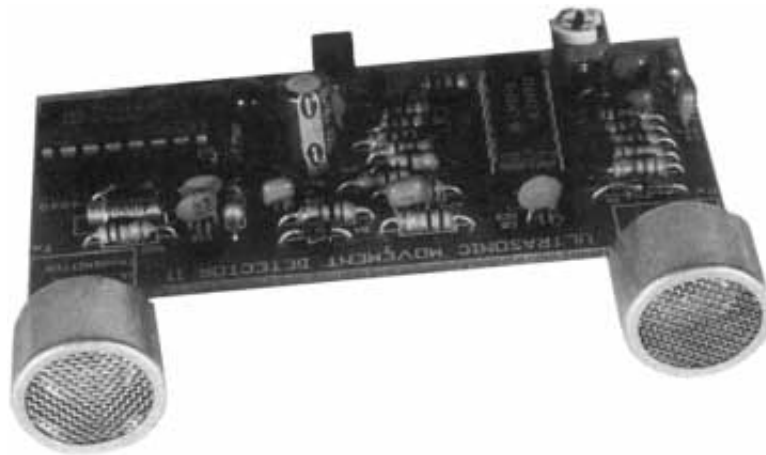

Ultrasonic Motion Detector

A simple circuit that lets you keep tabs on anything that moves.



BY RONALD A. REIS

Something's out there—on the porch, in the driveway, or behind the shed. Or maybe it's inside—in the garage, basement, or den. Whatever it is, human or beast, it is moving. Perhaps it's just your teenager sneaking in from a late night out. Possibly it is only the neighborhood cat. Or, more ominously, it could be a prowler bent on theft or physical harm. Whatever is going on, you know something is up

because you just installed the *Ultrasonic Motion Detector* described in this article.

Depending on what parts you have available, or if you buy the complete kit from the source mentioned in the Parts List, the Ultrasonic Motion Detector can be built for less than \$30. It contains a complete ultrasonic (40-kHz) crystal-controlled transmitter and a supersensitive receiver on a printed-circuit board that

measures only 1-1/2 by 3 inches.

The device detects motion from 4 to 7-meters away. Once that occurs, a red LED lights. But with additional circuitry attached to the output, the detector can turn on lights, sound buzzers, trip a recording device, or even call the police. Also, the circuit can be made to sound off with a message when anyone moves within its field of detection. Using various voice recording and playback circuits, you might even have the Ultrasonic Motion Detector provide a pleasant greeting or snarl with a barking dog sound when someone approaches the front door. As you can see, your Ultrasonic Motion Detector project can be put to work in a variety of ways. Let's now look at how it works.

Fig. 1. This is the schematic diagram for the Ultrasonic Motion Detector. When motion is sensed, transistor Q1 switches on, lighting LED1.

Circuit Description

The schematic for the Ultrasonic Motion Detector is shown in Fig. 1. A 9-volt battery, B1, directly provides power for some sections of the circuit. The battery is also connected to a 78L05 regulator, IC3, which provides a 5-volt-DC power source for other sections of the circuit.

The transmitter section of the Detector is basically a crystal-controlled relaxation oscillator built around a 4049 hex inverter, IC2. One of the 4049 sections, IC2-c, along with resistors R21 and R22, and capacitors C11 and C12, "pings" the 40-kHz crystal into sustained oscillation. The remaining 4049 sections act as linear buffers to drive a 40-kHz ultrasonic transmitting transducer, BZ2.

The receiver section of the circuit is made up of four AC-coupled stages, each

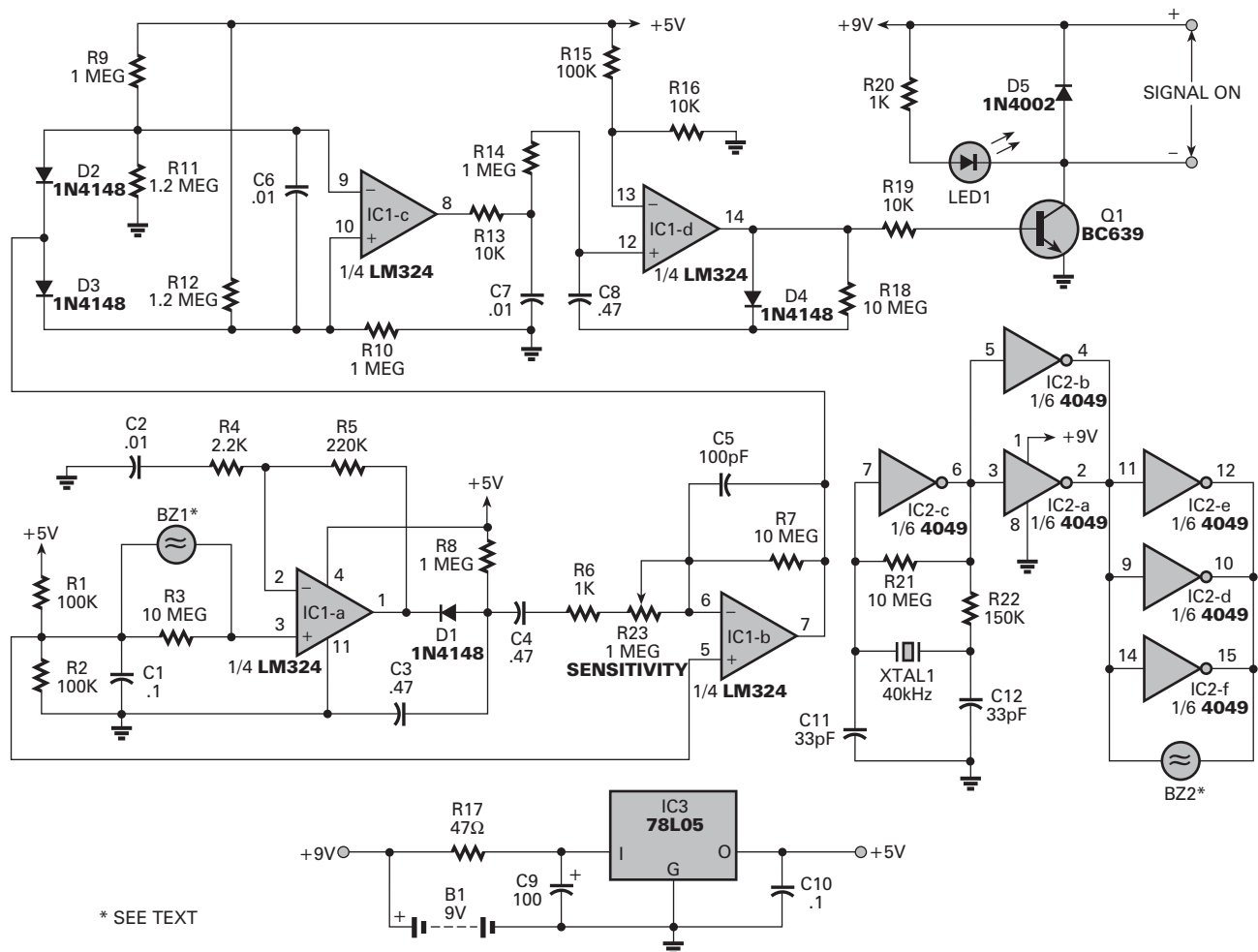

* SEE TEXT

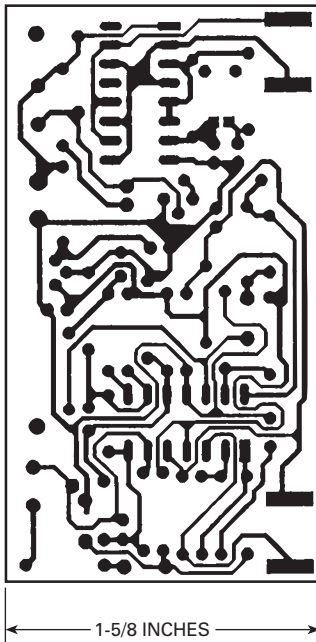

Fig. 2. *If you'd like to etch your own board, use this full-sized template.*

built around one of four sections of an LM324 op-amp IC1. In the first stage, the input voltage developed across R1 and R2 is modulated by a 40-kHz, ultrasonic receiving transducer, BZ1, and is then fed to IC1-a, where it is amplified. The receiving transducer detects any reflected sound produced by the transmitting transducer, BZ2. If there is no movement, the resulting envelope signal is just a straight line: diode D1 and resistor R8 operate as a negative peak detector to recover the envelope signal.

In the second stage, which is built around IC1-b, the recovered signal is again amplified. The time constant of IC1-b is quite slow so that the envelope can be followed; the output of the second stage is a DC level that represents the strength of the envelope. If there is movement, the envelope will reflect it in the form of a positive or negative signal.

At the input to the third stage—a differential amplifier built around IC1-c—there are two diodes, D2 and D3. They detect both positive and negative pulses. When there is no movement, the voltage at pin 7 of IC1-b is half the supply voltage and neither D2 or D3 can conduct. The voltage at pin 8 of IC1-c is then low. If the signal rises above +0.7 volt (a silicon diode's breakdown voltage), D3 conducts

causing the output on pin 8 to go high. If the signal falls below -0.7 volt, D2 conducts, which also causes the output to go high. Thus we have a window detector. It detects voltages that move both below and above a given range.

The fourth stage, built around IC1-d, is set up as a monostable flip-flop. That stage converts any signal that gets through the filter into a pulse substantial enough to turn on transistor Q1. When Q1 conducts, LED1 turns on and an output signal is provided to drive a separate relay or any other device connected to the circuit (more on that later). The time constant of the monostable flip-flop is about half a second and is set by C8 and R18. Diode D4 is used to separate the charge and discharge time constants. It lets the circuit switch on immediately when movement is detected, but allows about a half-second delay for the reset.

Construction

The author built the Ultrasonic Motion Detector from a complete kit of parts, which includes a pre-etched and drilled PC board. That kit is available from the source mentioned in the Parts List. If you choose to round up your own components, it is still recommended that you use a PC board. You can use the foil pattern shown in Fig. 2 to make your own.

Refer to the parts-placement diagram shown in Fig. 3 while assembling your circuit. Begin by soldering all resistors flush to the PC board. Then install the five diodes, making sure to orient them properly. Next, install the capacitors. Be sure to double check the polarity of C9.

Go on to install crystal XTAL1. Bend the crystal's leads so that the part rests flat on the board. Note the two unused holes next to the two for the crystal. You can bend a resistor lead around the crystal in a "U" shape and solder the lead ends to the unused holes. That should hold the crystal in place.

Install the potentiometer. Then continue by mounting the 78L05 voltage regulator and the BC639 transistor; those two parts look alike, so be careful not to

Fig. 3. When assembling the circuit, use this parts-placement diagram as a guide. Note that BZ1 and BZ2 surface-mount on the foil side of the board.

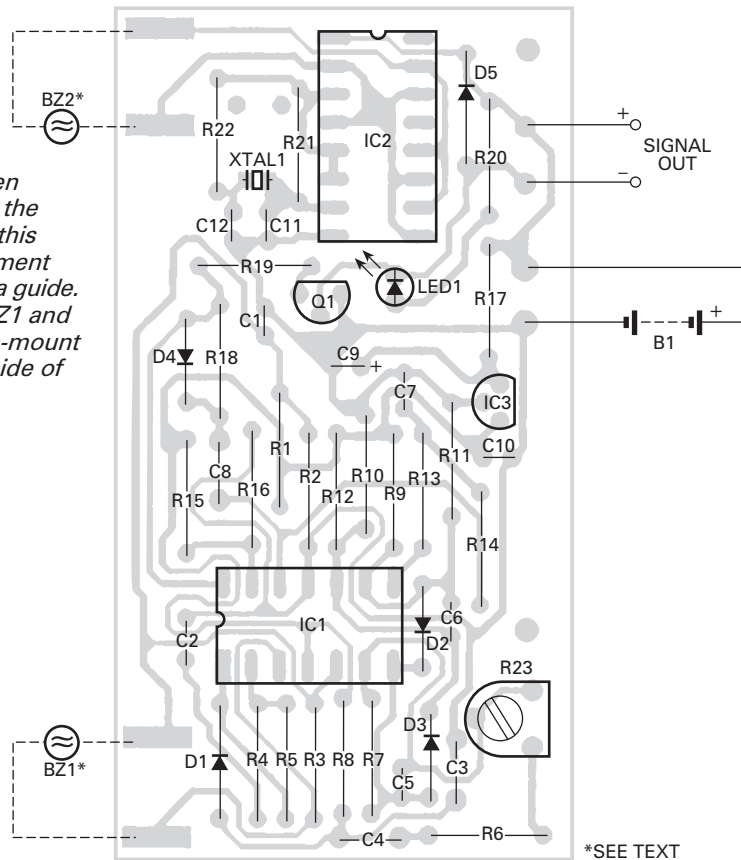

*SEE TEXT

confuse them. Also install LED1. Make sure all those parts are oriented as shown in the parts-placement diagram.

Now solder IC sockets for IC1 and to the board, noting the proper placement of the notches indicated in Fig. 3. Insert the ICs into their respective sockets. Connect the leads of the 9-volt battery clip to the board next. Now is a good time to note that if you do plan on using a battery to

power the project you have to replace the battery regularly. As the battery voltage decreases, the circuit's sensitivity will change; that is particularly true if the unit is triggered often. To avoid the extra expense of replacing batteries, you might want to replace the battery clip with two wires (red and black can be used to indicate polarity) so that you can hook up a 9-volt power supply.

Now you can install the ultrasonic transducer pair. If you are not building the project from the kit, you should make sure you are using a matched pair of 40-kHz transducers or the project will not work. You can get the "Transmitter/Receiver Pair" from Electronic Goldmine (PO Box 5408, Scottsdale, AZ 85261; Tel. 602-451-7454) as part-

number G5721. Contact them for more information.

The transmitting transducer, BZ2, has a T suffix on the number stamped underneath it. The receiving transducer, BZ1, has an R suffix. Neither part is polarized. Tag-solder each transducer on its proper pads directly on the foil side of the PC board. The leads should rest flat on the pads and the fronts of the transducers

Fig. 4. This simple circuit can be used with the Ultrasonic Motion Detector to provide a two-minute alarm tone when motion is detected.

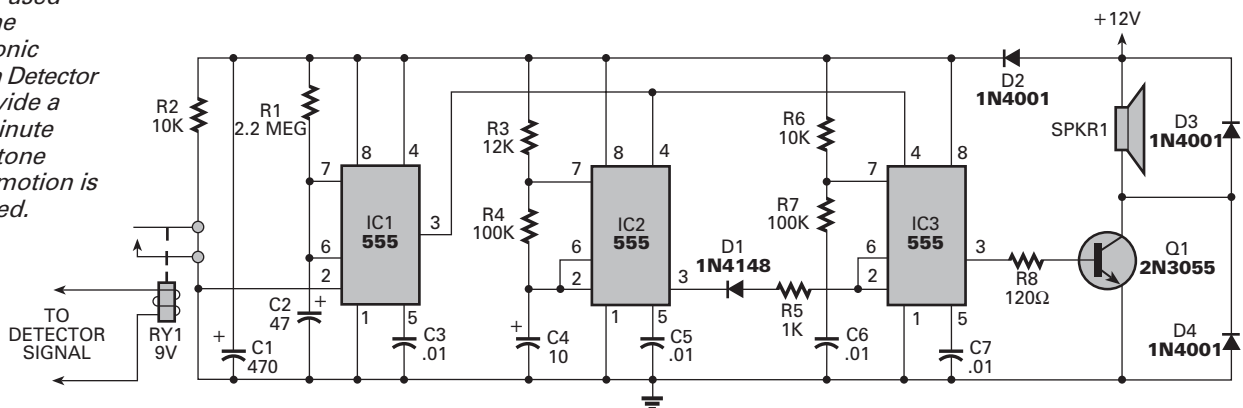

should point away from the PC board.

Finally, install two wires to provide a signal-out connection for attaching various output transducers and circuits. You might want to use one red and one black wire, as the signal is polarized.

Some Applications

Referring back to Fig. 1, note that transistor Q1 turns on and delivers a continuous unregulated 9 volts to a suitable load as long as something is moving within the Detector's range. If the load is a 9-volt relay, virtually any electronic device can be turned on in response to motion. That might be good enough for many applications—lights can be made to flash, horns to blare, etc. (If you have trouble driving the coil of a 9-volt relay, you might need to reduce the value of R19 in Q1's base circuit.)

However, there are times when you will want an output device to remain activated after motion has stopped. For example, if a prowler quickly crosses the field of "view," you wouldn't want a speaker to sound or a light to flash for just an instant. Continuous signaling, perhaps for many minutes, would be desirable.

The alarm circuit shown in Fig. 4 will provide such a warning. It consists of three 555 timer ICs, IC1-IC3, where IC1 is operated in a monostable mode, and IC2 and IC3 are in astable configurations.

The trigger input to IC1 (pin 2) is connected to the normally open contacts of a 9-volt relay. The coil of the relay should be connected to the signal output terminals on the PC board. When the Detector senses motion, even for a brief moment, the relay is energized, and pin 2 of IC1 (all part designations given from here on are found in Fig. 4) is brought to ground, thus triggering the monostable circuit, or timer. Pin 3 of IC1 then goes high. The length of time it remains high is determined by the values of R1 and C2. With the components shown, the output pulse is approximately 2 minutes. To increase that time, use a higher-value capacitor for C2; to decrease the time, use a lower-value capacitor.

When the output of IC1 goes high, IC2 and IC3 are activated. The latter timer, IC3, is connected to produce a 500-Hz tone; IC2 is a 1-Hz oscillator. Thus IC2 is used to trigger IC3 on and off once per second, generating a pulse-tone alarm. Note that the alarm circuit is run off a separate power supply from that used by the Detector.

Using an alarm circuit with your Motion Detector is only one application. Let your imagination fly; think of all the devices you can turn on (or off) when movement is sensed. Consider your project as the heart of a wide range of practical and fun applications.



PARTS LIST FOR THE ALARM CIRCUIT (Fig. 4)

SEMICONDUCTORS

IC1-IC3—555 timer, integrated circuit
Q1—2N3055 NPN transistor
D1—1N4148 silicon diode
D2-D4—1N4001 silicon rectifier diode

RESISTORS

(All resistors are 1/4-watt, 5% units.)
R1—2.2-megohm
R2, R6—10,000-ohm
R3—12,000-ohm
R4, R7—100,000-ohm
R5—1000-ohm
R8—120-ohm

CAPACITORS

C1—470- μ F, 16-WVDC, electrolytic
C2—47- μ F, 16-WVDC, electrolytic
C3, C5-C7—0.01- μ F, ceramic-disc
C4—10- μ F, 16-WVDC, electrolytic

ADDITIONAL PARTS AND MATERIALS

RY1—9-volt relay, normally open contacts
SPKR1—8-ohm speaker
Perforated board, IC sockets, wire, solder, hardware, etc.

PARTS LIST FOR THE ULTRASONIC MOTION DETECTOR (Fig. 1)

SEMICONDUCTORS

D1-D4—1N4148 silicon diode
D5—1N4002 silicon rectifier diode
IC1—LM324 quad op-amp integrated circuit
IC2—4049 hex-inverter integrated circuit
IC3—78L05 5-volt regulator integrated circuit
LED1—Light-emitting diode, red
Q1—BC639 NPN transistor (RCA SK3024, Radio Shack 276-2030, or equiv.)

RESISTORS

(All fixed resistors are 1/4-watt, 5% units.)
R1, R2, R15—100,000-ohm
R3, R7, R18, R21—10-Megohm
R4—2200-ohm
R5—220,000-ohm
R6, R20—1000-ohm
R8-R10, R14—1-Megohm
R11, R12—1.2-Megohm
R13, R16, R19—10,000-ohm
R17—47-ohm
R22—150,000-ohm
R23—1-Megohm potentiometer

CAPACITORS

C1, C10—0.1- μ F, ceramic-disc
C2, C6, C7—0.01- μ F ceramic-disc
C3, C4, C8—0.47- μ F ceramic-disc
C5—100-pF, ceramic-disc
C9—100- μ F, 16-WVDC, electrolytic
C11, C12—33-pF, ceramic-disc

ADDITIONAL PARTS AND MATERIALS

XTAL1—40-kHz crystal
BZ1—40-kHz ultrasonic receiving transducer (part of matched pair, see text)
BZ2—40-kHz ultrasonic transmitting transducer (part of matched pair, see text)
B1—9-volt battery (see text)
Printed-circuit materials, IC sockets, battery connector with leads, wire, solder, hardware, etc.

Note: The following is available from

Marlin P. Jones & Assoc., Inc.
PO. Box 12685
Lake Park, FL 33403-0685
Tel. 407-848-8236; Fax: 800-4FAXYES

Complete kit of parts, including printed-circuit board (6049-KT)—\$27.95 plus \$5.00 shipping and handling. Florida residents, please add 6% sales tax.

Copyright © 1997, POPtronix Inc.
All rights reserved.

As a service to readers, POPtronix, Inc. publishes available plans or information relating to newsworthy products, techniques and scientific and technological developments. Because of possible variances in the quality and condition of materials and workmanship used by readers, we disclaim any responsibility for the safe and proper functioning of reader-built projects based upon or from plans or information published online.

Since some of the equipment and circuitry described in POPtronix, Inc. Project Articles may relate to or be covered by U.S. patents, we disclaim any liability for the infringement of such patents by the making, using, or selling of any such equipment or circuitry, and suggest that anyone interested in such projects consult a patent attorney.