

Constructional Project

LOOP AERIAL SW RECEIVER

by ROBERT PENFOLD

You don't have to surf-the-net to capture the world. Just build this low-budget receiver and be amazed!

There have been electronic projects for just about everything imaginable published in recent years, but a simple shortwave (SW) receiver is still one of the most interesting electronic devices that you can build.

Commercial shortwave sets are now highly sophisticated pieces of electronics, and it is probably not feasible for the home constructor to compete with these. However, at the other end of the scale it is possible to produce simple and inexpensive receivers that are fun to build and will pick up numerous stations from around the world.

IN RANGE

The design featured here is intended for broadcast band reception at frequencies from about 4.5MHz to 14MHz. This provides coverage of the popular 49, 41, 31, 25, and 22 meter bands. It does not require an elaborate aerial or an earth connection, and the aerial is a form of loop antenna.

The term "loop" is perhaps not entirely appropriate in this case, because the aerial is actually about 2.5m of 300 ohm impedance ribbon feeder. This form of loop antenna has the advantage of being easy to accommodate, and it seems to provide quite strong output signals.

The loop is, in fact, about two

or three meters on one dimension and only about 10mm on the other, rather than a circle of around two meters in diameter, but this does not seem to have a drastic effect on performance. The output of the set is adequate to drive either a crystal earphone or a pair of medium impedance headphones.

This is a very simple design using just three transistors. There are no unusual coils to wind or buy because the loop aerial also acts as the tuning coil, so it is very easy to build.

TUNED CIRCUIT

The block diagram of Fig.1 shows the simple arrangement used in this *SW Receiver*. Conventionally, the aerial is a long piece of wire which has one end connected to the receiver and the other end left unconnected. The aerial provides signals over a wide range of frequencies and a filter must remove all except those signals that are close to the required reception frequency.

A sophisticated receiver has complex circuits to provide this filtering, but a simple receiver such as the one featured here has to rely on one simple filter. This is invariably a parallel tuned circuit, which is merely a capacitor connected in parallel with an inductor.

At a certain frequency, called the "resonant frequency", this type of circuit has infinite impedance. Away from the resonant frequency the impedance falls away rapidly to a low level. In effect, signals at or close to the resonant frequency are allowed to pass through to the subsequent stage while signals at other frequencies are short-circuited to earth.

In this design, the aerial and the inductor in the tuned circuit are one and the same. The aerial is a large single-turn inductor, and the size of the aerial determines its inductance. The capacitor in the tuned circuit is a variable type, and this permits the reception frequency to be varied over a wide frequency range. The aerial only operates efficiently at its resonant frequency and at nearby frequen-

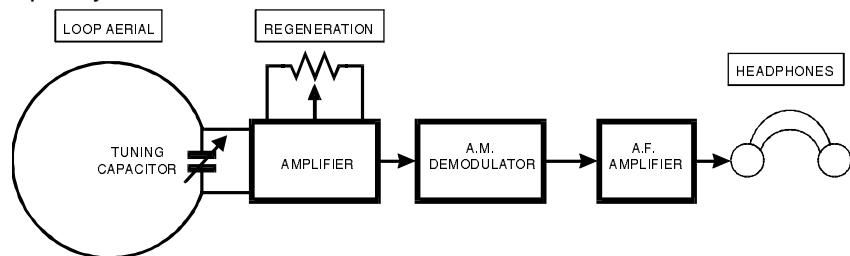

Fig.1. Block diagram for the simple Loop Aerial SW Receiver.



cies, and this gives much the same result as using a separate long-wire aerial and tuned circuit.

The output from the aerial feeds a two-stage amplifier that has a buffer stage to provide a high input impedance. This is essential, as loading on the tuned circuit would otherwise reduce its efficiency to the point where it would not give adequate bandpass filtering. The second stage of the amplifier provides a substantial amount of voltage amplification.

This very simple form of receiver has two main shortcomings, which are a lack of sensitivity and inadequate selectivity. A receiver's selectivity

is its ability (or lack of it) to pick out just one transmission from several stations on similar frequencies. Without some help a single tuned circuit does not provide adequate selectivity.

POSITIVE FEEDBACK

This help is in the form of positive feedback from the output of the amplifier to the tuned circuit at the input. As one would expect, this recycling of some of the signal provides an effective boost in gain, and improved sensitivity.

Less obviously, it also provides a great improvement in selectivity. This is due to the fact that there is more feedback at the center of the passband

than there is away from resonance where the receiver operates less efficiently. This feedback, or "regeneration" as it is normally called in this context, therefore provides a much higher boost in sensitivity at the center of the passband, narrowing the passband in the process.

There is a definite limit to the amount of feedback that can be used, and exceeding this limit results in the circuit breaking into oscillation. Optimum results are obtained with the regeneration control set just below the point at which oscillation occurs.

The output from the amplifier is fed to a conventional a.m. demodulator that recovers the audio signal from the received RF (radio frequency) carrier wave. Even on strong signals the output level from the demodulator will be quite low, and an audio amplifier is therefore used to boost this signal to a more usable level. Good volume is obtained from a crystal earphone or medium impedance headphones.

CIRCUIT OPERATION

The complete circuit diagram for the *Loop Aerial SW Receiver* is shown in Fig.2. L1 is the loop

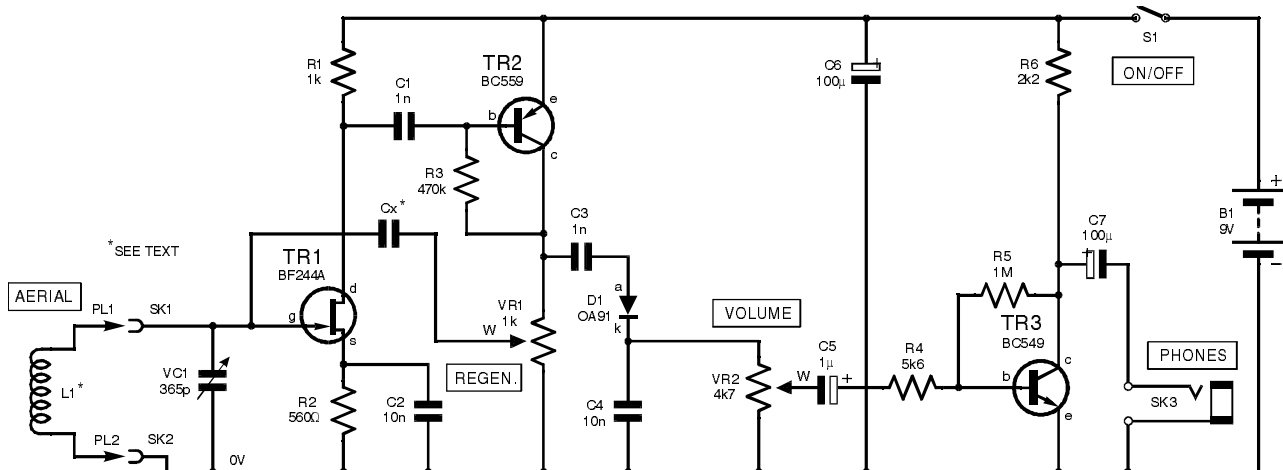

Fig.2. Complete circuit diagram for the Loop Aerial SW Receiver. The loop aerial is a single "loop" of about 2.5m of 300 ohm feeder cable (full details can be found in Fig.3)

COMPONENTS

Resistors

R1 1k
R2 560 ohms
R3 470k
R4 5k6
R5 1M
R6 2k2

All 0.25W 5% carbon film

Potentiometers

VR1 1k rotary carbon, linear
VR2 4k7 rotary carbon, logarithmic

Capacitors

C1, C3 1n Mylar (2 off)
C2, C4 10n ceramic (2 off)
C5 1u radial electrolytic, 50V
C6, C7 100u radial elect. 10V (2 off)
VC1 365p variable (see [Shoptalk](#))
Cx twisted lead (see text)

Semiconductors

D1 OA91 germanium signal diode
TR1 BF244A *n*-channel JFET
TR2 BC559 *pnp* silicon transistor
TR3 BC549 *nnp* silicon transistor

Miscellaneous

S1 s.p.s.t. miniature toggle switch
B1 9V (PP3) battery (see text)
SK1, SK2 2mm or 4mm socket (2 off)
SK3 3.5mm jack socket (see text)
PL1, PL2 2mm or 4mm plug to match sockets SK1, SK2 (2 off)
L1 300 ohm ribbon feeder (approx. 2.5m) for aerial loop (see text)

Metal instrument case (see text);
0.1 inch pitch stripboard, size 31 holes x 20 copper strips; control knob (3 off); crystal earphone or headphones (see text); battery connector; wire; solder pins; solder, etc.

**See also the
SHOP TALK Page!**

Approx. Cost **\$18**
Guidance Only
(Excl. batt. & variable cap)

aerial itself, and VC1 is the tuning capacitor. TR1 is a junction gate field effect transistor (JFET) which is used here in the common source mode. Unlike an ordinary bipolar transistor, a JFET requires a reverse bias in order to provide linear amplification.

Resistor R2 results in the source(s) of TR1 being taken to about 0.5 volts or so positive, while aerial coil L1 biases the gate (g) input to the 0V rail and provides the small reverse bias. Bypass capacitor C2 removes the negative feedback that would otherwise be introduced by R2.

Transistor TR1 provides a certain amount of voltage gain, but its main purpose is to provide a high load impedance for the tuned circuit. A high input impedance is a natural characteristic of a JFET and other field effect devices.

GAIN

Most of the voltage gain is provided by *pnp* transistor TR2, which operates as a simple common emitter amplifier. Regeneration control VR1 enables a controlled amount of feedback to be provided over the entire amplifier via capacitor Cx. The value of Cx is extremely low, and it is not actually a "proper" capacitor. It is simply two short pieces of insulated wire twisted together.

Capacitor C3 couples the output of TR2 to a conventional diode demodulator, which has D1 and C4 to respectively provide the rectification and the smoothing. The amplitude of the carrier wave is proportional to the audio signal voltage.

On the face of it, simply using some lowpass filtering will give an output signal that is equal to the average signal level, and therefore provides the required audio output signal. In practice this would not happen, because the carrier wave is an AC signal, and the positive half cycles balance the negative half cycles to give an average output voltage of zero. Removing one set of half cycles eliminates this balancing,

and gives the required demodulation.

Potentiometer VR2 is the "load resistor" for the demodulator and is also the volume control. From here the signal is coupled, via C5, to a common emitter amplifier based on transistor TR3. The output power available from TR3 is not very great, but it is sufficient to drive a crystal earphone. It will also drive medium impedance headphones if the phones are connected in series. Other types of headphone and earphone are unlikely to provide acceptable results.

The current consumption of the circuit is around 12mA or so. A good quality PP3 size battery is adequate to power the set, but if it is likely to receive a great deal of use it would be more economic to use six AA-size cells in a holder.

CONSTRUCTION

This simple receiver circuit is built up on stripboard and the component layout and wiring, together with the underside view showing breaks in the copper tracks, are shown in Fig.4. The board measures 31 holes by 20 copper strips, but it is not sold in this size.

Commence construction by cutting a larger piece of board to size using a hacksaw, cutting along the rows of holes. This produces some rough edges but they are easily filed to a neat finish.

Next, the two 3mm diameter mounting holes are drilled in the board and the three breaks in the copper strips are made. A special tool for cutting copper strips is available, but a hand-held twist drill of about 5mm in diameter does the job quite

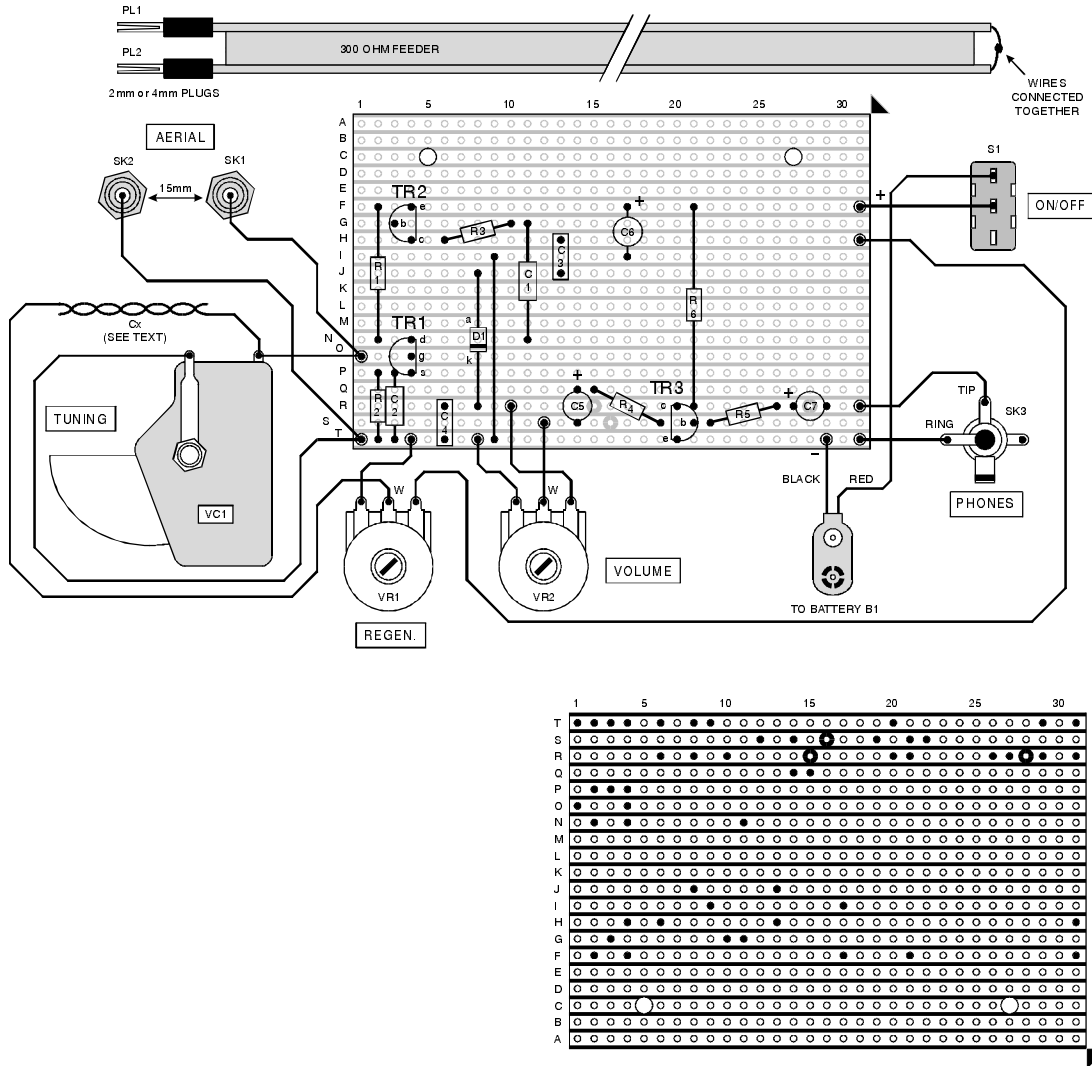

Fig.3. Stripboard component layout, off-board interwiring, and board underside showing breaks in copper tracks. "Loop" aerial details are shown at the top and the completed circuit board above.

well. Whatever tool you use, make sure that the strips are broken across their full width.

The board is now ready for the components to be fitted. Fit the resistors and capacitors first, making sure that the three electrolytic capacitors have the correct orientation. Use single-sided solder pins at the points where connections to the sockets, controls, and battery clip will be made.

Finally, fit the semiconduc-

tors, making sure they have the correct orientation. Diode D1 is a germanium device, which is more easily damaged by heat than the usual silicon devices such as TR1 to TR3. It should not be necessary to use a heat-shunt when connecting this component, but make sure that the soldered joints are completed quickly. Having connected one lead, allow a few seconds for the component to cool down before connecting the other lead.

CASING-UP

Shortwave receivers are traditionally built into metal cases, but this design does not rely on the case to carry any connections and it can be housed in a plastic case if preferred. It is important to keep the wiring reasonably short, and it is probably best not to depart too far from the general layout used for the prototype (see photographs).

VARIABLES

It is advisable to use a large control knob on tuning control VC1, because this makes accurate tuning easier, but it will necessitate the use of a fairly tall case. Ideally, VC1 would be a high quality air-spaced variable capacitor such as a 365pF Jackson type "O".

Unfortunately, components of this type tend to be very expensive, and some of the solid dielectric types (as used on the prototype) are not much better in this respect. Probably the best low-cost option, if you can find one, is to use a good quality "surplus" air-spaced component. Any maximum value from about 250pF to 500pF will do.

Another alternative is to use a low cost solid-dielectric component, such as used in "transistor radios". These usually have two "AM" sections, which are used in parallel (i.e. wire the two non-earth terminals together). Any low value "FM" sections can be wired in parallel with the "AM" sections or just left unused.

Some variable capacitors require the usual 10mm diameter mounting hole, but most are fixed to the front panel using two or three short screws that fit into threaded holes in their front plates. With this second type it is often easier to glue them in place using a good quality adhesive such as an epoxy type. If longer fixing screws are used, make sure they do not penetrate so far into the front plate that they damage or foul the vanes.

SOCKETS

Sockets SK1 and SK2 are mounted on the rear panel of the case, and they must be

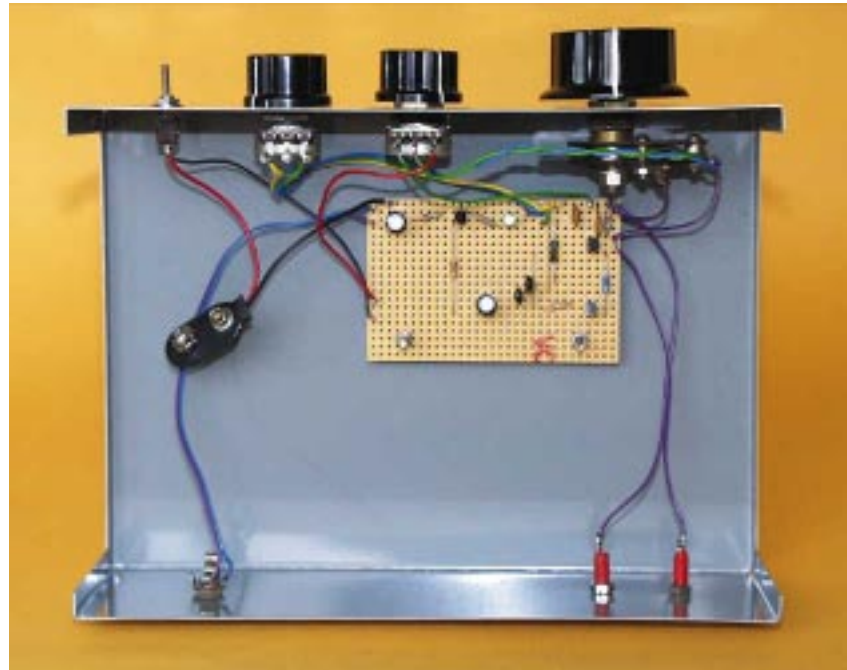

Suggested component layout and wiring inside the prototype metal case. The aerial and headphone sockets are mounted on the rear panel. Space must be allowed for a 6-cell AA-size battery pack if the receiver is to be used regularly.

quite close together (a gap of 15mm is about right). If the set will be used with a crystal earphone, SK3 must be a 3.5mm jack socket, which matches the plugs normally fitted to this type of earphone. The switch contact fitted to open style sockets of this type is not required in this case, and one tag is therefore left unused.

A 3.5mm stereo socket is required for medium impedance

headphones of the type sold as replacements for use with "Walkman" style units. These sockets are available in several styles, and the retailer's literature should include connection information. The 'phones are used in series, which means that the common earth tag is left unconnected and the board is wired to the other two tags.

The circuit board is mounted on the base panel of the case using metric M2.5



screws. Include spacers about 6mm long between the board and the case.

The wiring is perfectly straightforward, see Fig.3, apart from capacitor Cx. Ideally this would be made from two pieces of single-strand insulated wire, but ordinary multi-core connecting wire will do. Simply twist the ends of the wires together so that they are entwined over a length of about 50mm. If you use multi-core wire, it is advisable to wrap some tape around the wires to ensure that everything stays in place.

AERIAL

Details of the aerial are also provided in Fig.3. A 2.5 meter length of 300 ohm ribbon feeder provides the approximate frequency coverage specified previously. Alternatively, you can use two aerials of different lengths to give the receiver two bands, and broaden its frequency coverage.

Band changing is then achieved by unplugging one aerial and connecting the other instead. This is a rather crude way of doing things, but is essentially the same as the plug-in coil method that has traditionally been used for simple short-wave receivers.

Realistically, the receiver is unlikely to perform well at very high frequencies, and there are relatively few AM broadcast stations to be found on the low frequency bands. One aerial about 1.5 meters long and one about 3.5 meters in length will provide coverage of the broadcast bands from 60 meters to 13 meters. Using 300 ohm ribbon feeder is not particularly expensive, so you might like to experiment with aerials of various lengths to see what, if anything,

can be received at higher and lower frequencies.

It is very easy to make the aerial. Start by removing about 25mm of the plastic "ribbon" at each end of the cable using a sharp modeling knife, taking due care not to cut either yourself of the wires in the cable.

Using ordinary wire strippers remove a few millimeters of insulation from each end of both wires, and "tin" the exposed ends with solder. At one end of the cable solder the two wires together to close the loop. At the other end of the cable fit two 2mm or 4mm plugs to match the type of socket used for SK1 and SK2.

IN USE

After a final check of the wiring it is time to connecting everything together and test the receiver. The aerial will not work well if it is left in a crumpled heap, but on the other hand it does not have to be kept perfectly straight. The prototype worked well with the aerial at about 30 degrees to the horizontal with the far end fixed to a cupboard with a piece of Bostik Blu-Tack.

With Regeneration control VR1 fully backed-off in a counter clockwise direction and Volume control VR2 well advanced, it will probably be possible to receive a few stations, but not very well. Accurate adjustment of the Regeneration control is crucial if good results are to be obtained. Advancing this control should give much improved results with better sensitivity and selectivity.

However, as explained previously, advancing the Regeneration control too far results in the set breaking into oscillation. This will be heard as increased

noise in the headphones, and a tone of varying pitch as the set is tuned across a station.

Optimum results are obtained with the Regeneration control backed off just far enough to bring the set out of oscillation. Any large changes in the setting of tuning control VC1 will probably require some readjustment of the Regeneration control in order to maintain good results.

RECEPTION

The main shortwave broadcast bands will provide a range of interesting stations at practically any time of the day. Bear in mind though, that reception is at the mercy of the upper atmosphere, and is affected by factors such as the weather, sunspot activity, and the time of year. At times reception may be exceptionally good, while at other times the bands might provide few signals at all.

Normally, in the UK, it will be possible to receive stations from all over Europe, plus perhaps a few stations in North Africa, the Middle East, etc. When conditions are favorable it is possible to receive stations from much further afield.

You do not have to be a linguist to follow some of the programs, as many countries put out programs in English. For example, one of the first transmissions heard when testing the prototype was an English language broadcast from Turkey!

[Go to next section](#)