

Overvoltage Protection for the LM317

Description:

This is an add-on Over Voltage Circuit for the LM317 Regulator Circuit submitted by Matthew Hewson. The original circuit may be viewed [here](#).

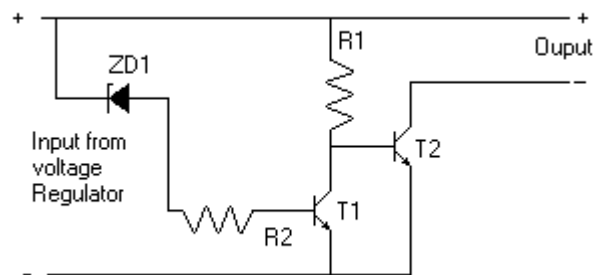

Notes:

It is a voltage regulator that allows a 6v portable supply to be derived from the 12v car battery. You can add a 6.2V zener diode and a LED to warn you when the input supply is overvoltage. If you could find a relay that would operate from 6.2v right up to 12v that you could connect in such a way that if over voltage occurred, then the relay would automatically switch off the output preventing damage to any connected equipment.

Such a relay would be quite difficult to find, so I designed this, it is a simple two transistor circuit which will switch off the output should the voltage raise above 6.2v (this can be changed by selecting a different value of zener diode).

Components are as follows:

ZD1 =3D 6.2v Zener diode (you can change this to any value, the circuit will switch off the output if the input voltage raises above the value of the zener diode)

R1 = 1K Resistor (this can be of any power rating, it carries very little power)

R2 = 1K Resistor (this can be of any power rating, it carries very little power)

T1 = Low power NPN Transistor (BC108 or BC547 will do fine)

T2 = NPN transistor transistor capable of switching the equipment you are running (BFY51 or BC140 can switch 1 Amp, which is the maximum the voltage regulator circuit can handle)

It is advisable to test this circuit with a voltmeter, slowly increasing the voltage on the regulator circuit and make sure that this circuit switches off the output when the value of the zener diode is reached, before plugging in your expensive equipment. This circuit is intended to be used with the voltage regulator posted by Matthew Hewson, my overvoltage add-on circuit is shown with the original below:-

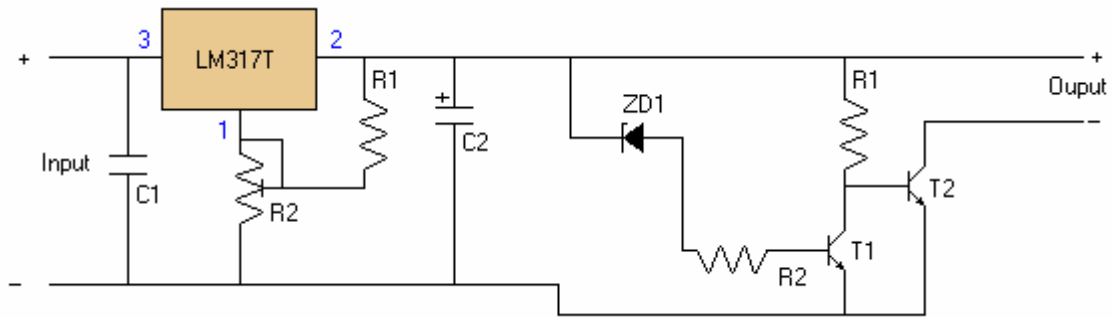

Double check the polarity, It is very easy to blow up components in the equipment that you are powering if you reverse the polarity. Also, if you want to increase the power output of the voltage regulator circuit above 1 Amp then connect several LM317's in parallel, be sure to make sure that transistor T2 on this circuit is of a high enough rating if you do this.

If you have any problems with this circuit, you can email me at: electronicplanetuk@hotmail.com or have a look for updates on my <http://www.electronics.vze.com/Adam>