

©2009

©2009

Copyright © January 28th 1996 Brought to you by Unitech Electronics Pty. Ltd.

[← Go Back](#)

[BOTTOM ↓](#)

[NEXT →](#)



Following in the footsteps of the "primitive" but quite successful 4 pin **OM802** timer IC manufactured by Philips semiconductor way back in 1969, a new and very innovative IC known as the NE-555 timer IC was released to the masses, being introduced around May 1971 by the then Signetics Corporation, to become known as the NE-555 / SE-555. It was called "**The Ubiquitous Timer chip**" and was also the very first very mass-produced commercially produced timer IC available at that time. The designers had no real idea what product life it would have, nor how brilliantly successful it would be, lasting well over 25 years still in mass-production today. [1971- 1996]

The NE-555 would prove to be a " hit " and provide Electronic Engineers, Circuit Designers and a host of "Hobby Tinkerers" with a relatively novel and highly economical timer chip that was indeed very stable at timing all the way up to its maximum timing or oscillating frequency of 200KHz and in a very short time proved to be a very "user-friendly" timer integrated circuit for both simple and complex monostable as well as brilliant astable applications. Invented by a clever Swiss born gentleman by the name of Hans R. Camenzind in 1970, the NE-555 went on to become a legend in the industry,

Since this versatile device became commercially available in May 1971, a plethora of highly innovative and very unique and "ever-so-ingenuous" circuits has emerged and many circuits have been developed and demonstrated to the "N-th" degree in a variety of reputed "trade-only" journals, professional "Engineering Monthly" Journals as well as the vast numbers of excellent hobbieist publications globally, the likes of SILICON CHIP (SC) and ELEKTOR , Practical Electronics (PE) , Electronics Australia (EA) and Electronics Today International (ETI) to name but just a few. During the past twelve or so years, some " 555 " manufacturers have ceased making these rather unique timers because of market competition or for pure economical reasons.

Update: 29th March 2003

Please note: Electronics Australia (EA) and Electronics Today International (ETI) have ceased to be published, leaving only the brilliant "mag" SILICON CHIP (SC) SILICON CHIP is now the only electronics magazine published in Australia. S.C. is available each month from your local newsagent or directly mailed from the publisher by subscription or from all Jaycar Stores across Australia (ring first as it moves quickly off the shelf) .

[TOP ↑](#)

Many other companies, like [N.T.E.](#) (a subdivision of Philips) picked up where some "left off". This article is about this fantastic little timer IC which is, after 25 years still very popular today and used in many schematics. Slowly the new generation of "useful chips" called PIC chips is taking over for many functions, these seem to be the greatest thing since the introduction of the now famous "555". The PIC Chip has the brilliant capability of being able "programed just like a CPU and to be custom tailored via very small and byte efficient programs to execute a myriad of unique functions, from sirens, monitoring etc. to very accurate timers however, this article deals with and only with the "555" applications and easy to setup usefulness of this unique chip. [1971- 1996]

Although these days the CMOS version of this IC, like the [Motorola](#) MC1455, is mostly used, the regular type is still available, however there have been many improvements and variations in the "internal" circuitry since 1971 ! With all these various "hidden" improvements within the various NE-555's manufactured, the main NE-555 package is still very much pin-for-pin compatible with every other NE-555 on the market today, this also includes the NE-7555 a later marketed CMOS version of the NE-555.

The aim within this simple tutorial is to show in some easy to comprehend detail, exactly how the NE-555 timer is correctly used.

The standard NE-555 can be a stand-alone compact device, yet powerful enough to perform basic timing functions or as a versatile timer or even as a simple oscillator to create tones of various pitches up to the ultrasonics of 200KHz or when combined with other ancillary circuitry employing gates or transistors for current switching or with other solid state devices without the mandatory requirement of an electronics engineering degree. This timer uses about 25 transistors to perform the tasks and is coupled with various diodes and resistors all on the NE-555's substrate "die" to do their bit in switching and timing and for this task with the minimum of components. Here is shown a more simplified (but quite accurate) block diagram to explain the basic internal organizations of the NE-555.

[TOP ↑](#)

MANUFACTURER	TYPE NUMBER
ECG PHILIPS	ECG855M
EXAR	XR-555
FAIRCHILD	NE555
HARRIS	HA555
INTERSIL	SE555 / NE555
LITHIC SYSTEMS	LC555
MAXIM	ICM7555
MOTOROLA	MC1455/MC1555
NATIONAL SEMICONDUCTOR	LM1455/LM555C
NTE	NTE955M
PHILIPS	SE555 / NE555
RAYTHEON	RM555/RC555
RCA	CA555/CA555C
SANYO	LC7555
SIGNETICS	NE555/SE555
TEXAS INSTRUMENTS	SN52555 / SN72555

www.unitechelectronics.com

TABLE 1

The first type-number, in Table 1 on the left, represents the type which was / is preferred for military applications which have somewhat improved electrical and thermal characteristics over their commercial counterparts, but also a bit more expensive, and usually metal-can or ceramic casing. This is analogous to the 5400 / 7400 series convention for TTL integrated circuits.

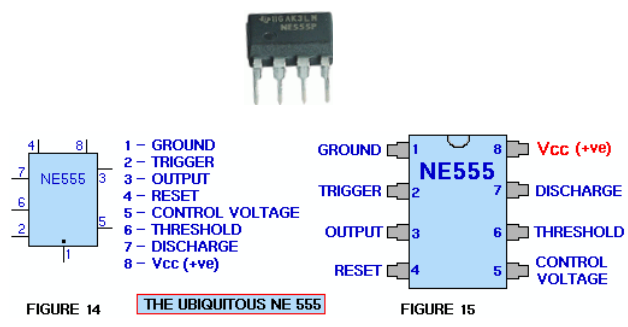

FIGURE 14 THE UBIQUITOUS NE 555

FIGURE 15

TOP ↑

The NE-555, in figure 14 and figure 15 (above) is supplied in a plastic package. It is believed that the round metal-can called the 'T' package or the "tin-can" is no longer available in favour of the more familiar and cheaper to produce 8-pin DIP "plastic" package. About 20-years ago the "T" metal-can type was very much the standard SE555 and NE-555 types. The NE-556 timer is a dual version of the NE-555 and comes in a standard 14-pin DIP plastic package. The NE-558 was a quad version of the NE-555 with four distinct NE-555's within the one package, incidently in a 14 pin DIP case, however it is scheduled to be discontinued due to its lack of popularity and also more importantly, its inherent internal problems.

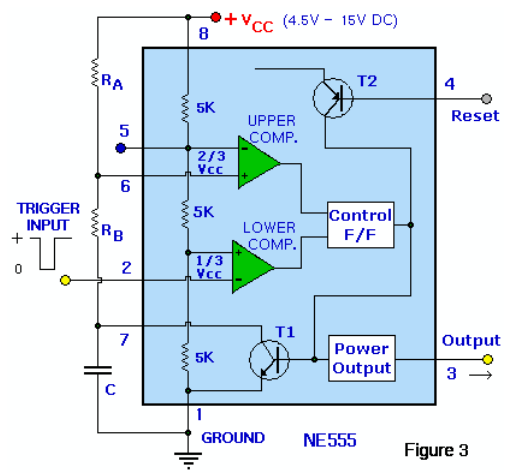

Figure 3

TOP ↑

Inside the NE-555 timer, in figure 3 (above) are the equivalent of over 26 transistors, 15 resistors, and 2 diodes, depending of the manufacturer. The equivalent circuit depicted here in block diagram, shows the provision of the functions of "control", "triggering", "level sensing" or "comparison", "discharge" and most importantly, the "power output". You will note it got its "NE-555 Name" from the three 5K resistors which form a voltage divider. Some of the more attractive features of the NE-555 timer are: Supply voltage between 4.5 volts and 18 volt, supply current 3 to 6 mA and a Rise / Fall time of 100 nSec. The NE-555 performs best with a stable supply voltage with filter capacitors to keep the "lines" clean. It can also withstand quite a bit of abuse. Note in Figure 3 (above) the common threshold current determined by the maximum value of $R_a + R_b$. For typical maximum 15 volt operation the maximum total resistance for R ($R_a + R_b$) is 20 Meg-ohm, please bare this in mind.



The supply current, when the output is 'high', is typically around 1mA (milli-Amp) or less. According to the specs, the initial monostable timing accuracy is typically within 1% of its "calculated" value, and exhibits negligible (0.1%/V) drift with regards to supply voltage. Thus it can be realised that long-term supply variations can be basically ignored and the temperature variation is only 50ppm / °C (0.005% / °C).

R - C Networks

All IC timers rely upon an external capacitor to determine the off-on or on-to off time intervals of the output pulses. You may recall from your own personal experiences in a study of basic electronics, it takes a finite period of time for a capacitor (C) to charge or to discharge exponentially through a resistor (R). Those times are clearly defined and can be calculated given the values of resistance and capacitance.

The basic RC charging circuit is shown in fig. 4.(below) So, assuming for a moment that the capacitor (C) is initially discharged, when the switch is closed, the capacitor begins to charge through the resistor via Ra and RB. The voltage across the capacitor rises from zero up to the value of the applied DC voltage.

The charge curve for the circuit is shown in fig. 6. The time that it takes for the capacitor to charge to approx. 63% of the applied voltage is known as the time constant (t). That time can be calculated with the simple expression:

Looking at the voltage charge versus time curve in figure 6, you can see that it takes approximately "5 complete time constants" for the capacitor to charge to almost the applied voltage. Theoretically, it would take about 5 seconds for the voltage on the capacitor to rise to approximately the full 6.0 volts.

TOP ↑

The ground (Earth or common) pin is the negative (-ve) voltage supply of the device, which is connected to circuit common (ground) when operated from positive (4.5V - 15V DC) supply voltages.

[TOP ↑](#)

Pin 2 (Trigger):

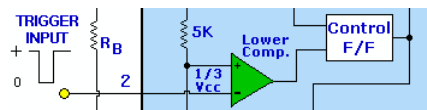

Pin 2 is the "input" to the lower comparator and is used to set the latch, which in turn causes the output to go high. This is the beginning of the timing sequence in monostable operation and triggering is accomplished by taking the pin from above to below a voltage level of $1/3 V_+$ (or, in general, one-half the voltage appearing at pin 5). The action of the trigger input is level-sensitive, allowing slow rate-of-change waveforms, as well as pulses, to be used as trigger sources.

The trigger pulse must be of shorter duration than the time interval determined by the external R and C. If this pin is held low longer than that, the output will remain high until the trigger input is driven high again. One precaution that should be observed with the trigger input signal is that it must not remain lower than $1/3 V_+$ for a period of time **longer** than the timing cycle.

If this is allowed to happen, the timer will re-trigger itself upon termination of the first output pulse. Thus, when the timer is driven in the monostable mode with input pulses longer than the desired output pulse width, the input trigger should effectively be shortened by differentiation.

The minimum-allowable pulse width for triggering is somewhat dependent upon pulse level, but in general if it is greater than the 1 μ S (micro-Second), triggering will be reliable. A second precaution with respect to the trigger input concerns storage time in the lower comparator.

This portion of the circuit can exhibit normal turn-off delays of several microseconds after triggering; that is, the latch can still have a trigger input for this period of time **after** the trigger pulse. In reality this means the minimum "monostable" output pulse width should be in the order of 10 μ S (micro-seconds) to prevent possible double triggering due to this effect.

The voltage range that can safely be applied to the trigger pin is between V_+ and ground. A "dc current", termed the **Trigger** current, must also flow from this terminal into the external circuit. This current is typically around 500nA (nano-Amp) and will define the upper limit of resistance allowable from pin 2 to ground.

For an astable configuration operating at $V_+ = 5$ volts, this resistance is 3 Mega-ohm, however it can be greater for higher V_+ levels.

[TOP ↑](#)

Pin 3 (Output):

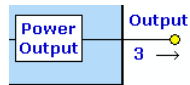

The output of the NE-555 comes from a high-current totem-pole stage made up of transistors Q20 - Q24. Transistors Q21 and Q22 provide drive for source-type loads, and their Darlington connection provides a high-state output voltage about 1.7 volts less than the V_+ supply level used. Transistor Q24 provides current-sinking capability for low-state loads referred to V_+ (such as typical TTL inputs). Transistor Q24 has a low saturation voltage, which allows it to interface directly, with good noise margin, when driving current-sinking logic.

Exact output saturation levels vary markedly with supply voltage, however, for both high and low states. At a V_+ of 5 volts, for instance, the low state V_{ce} (sat) is typically 0.25 volts at 5 mA. Operating at 15 volts, however, it can sink 200mA if an output-low voltage level of 2 volts is allowable (power dissipation should be considered in such a case, but of course). They do get quite hot and therefore stability will be an issue at higher than normal operation temperatures. We suggest buffering the pin 3's "load" with a transistor (and drive resistor) with the desired current switching in mind from pin 3.

High-state level is typically 3.3 volts at $V_+ = 5$ volts; 13.3 volts at $V_+ = 15$ volts. Both the rise and fall times of the output waveform are quite fast, typical switching times being 100nS. In doing your timing/switching experiments, always observe the switching characteristics on a C.R.O.

The state of the output pin will always reflect the inverse of the logic state of the latch, and this fact may be seen by examining **Figure 3**.

Since the latch itself is not directly accessible, this relationship may be best explained in terms of latch-input trigger conditions. To trigger the output to a high condition, the trigger input is momentarily taken from a higher to a lower level. [see "Pin 2 - Trigger"]. This causes the latch to be set and the output to go high. Actuation of the lower comparator is the only manner in which the output can be placed in the high state. The output can be returned to a low state by causing the threshold to go from a lower to a higher level (see "Pin 6 - Threshold"), which resets the latch.

The output can also be made to go low by taking the reset to a low state near ground (see "Pin 4 - Reset"). The output voltage available at this pin is approximately equal to the V_{cc} applied to pin 8 minus 1.7V.

[TOP ↑](#)

Pin 4 (Reset):

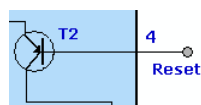

This pin is also used to reset the latch and return the output to a low state. The reset voltage threshold level is 0.7 volt, and a sink current of 0.1mA from this pin is required to reset the device. These levels are relatively independent of operating V_+ level, thus the reset input is TTL compatible for any supply voltage.

The reset input is an overriding function; that is, it will force the output to a low state regardless of the state of either of the other inputs. It may thus be used to terminate an output pulse prematurely, to gate oscillations

from "ON" to "OFF", etc.

Delay time from reset to output is typically on the order of 0.5 μ s, and the minimum reset pulse width is 0.5 μ s. Neither of these figures is guaranteed, however, and may slightly vary from one manufacturer to another.

In short, the reset pin is used to reset the flip-flop that controls the state of output pin 3. The pin is activated when a voltage level anywhere between 0 and 0.4 volt is applied to this pin. The reset pin will force the output to go low no matter what state the other inputs to the flip-flop are in. When not used, it is recommended that the reset input be tied to V+ to avoid any possibility of false resetting.

TOP ↑

Pin 5 (Control Voltage):

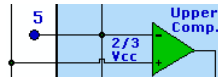

This pin allows direct access to the 2/3 V+ voltage-divider point, the reference level for the upper comparator. It also allows indirect access to the lower comparator, as there is a 2:1 divider (R8 - R9) from this point to the lower-comparator reference input, Q13. Use of this terminal is the option of the user, but it does allow extreme flexibility by permitting modification of the timing period, resetting of the comparator, etc.

When the NE-555 timer is used in a voltage-controlled mode, its voltage-controlled operational ranges from approximately 1 volt less than V+ down to within 2 volts of ground, although this is not guaranteed in the spec sheet. Voltages can be safely applied outside these limits, but they should be confined within the limits of V+ and ground for reliability.

By applying a voltage to this pin, it is possible to vary the timing of the device independently of the RC network. The control voltage may be varied from 45 to 90% of the Vcc in the monostable mode, making it possible to control the width of the output pulse independently of R - C. When it is used in the astable mode, the control voltage can be varied from 1.7V to the full 15V +Vcc.

By varying the voltage in the astable mode will produce a frequency modulated (FM) output. In the event the control-voltage pin is not used, it is recommended that it be bypassed, to ground, with a capacitor of about 0.01 μ F (10nF) for immunity to noise, since it is a comparator input. This factor is not quite obvious in many NE-555 circuits since we have seen many circuits with 'no-pin-5' connected to anything, however this is the proper procedure. The small ceramic cap may eliminate false triggering and let's face it, they are cheap.

TOP ↑

Pin 6 (Threshold):

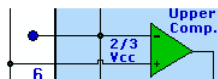

Pin 6 is one input to the upper comparator (the other being pin 5) and is used to reset the latch, which causes the output to go low.

Resetting via this terminal is accomplished by taking the terminal from below to above a voltage level of 2/3 V+ (the normal voltage on pin 5).

The action of the threshold pin is level sensitive, allowing slow rate-of-change waveforms.

The voltage range that can safely be applied to the threshold pin is between V+ and ground.

A "dc current" termed the **threshold** current must also flow into this terminal

from the external circuit. This current is typically to the order of 0.1 μ A, and will define the upper limit of total resistance allowable from pin 6 to V+.

For either timing configuration operating at V+ = 5 volts, this resistance is 16 Mega-ohm.

For 15 volt operation, the maximum value of resistance is **20 MegaOhms**.

TOP ↑

Pin 7 (Discharge):

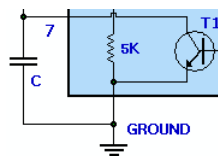

This pin is connected to the open collector of a npn transistor (Q14), the emitter of which goes to ground, so that when the transistor is turned "on", pin 7 is effectively shorted to ground. Typically the timing capacitor C1 is connected between pin 7 and ground and is discharged when the transistor turns "on". The conduction state of this transistor is identical in timing to that of the output stage.

It is "on" (low resistance to ground) when the output is low and "off" (high resistance to ground) when the output is high. In both the monostable and astable time modes, this transistor switch is used to clamp the appropriate nodes of the timing network to ground. Saturation voltage is typically below 100mV (milli-Volt) for currents of 5 mA or less, and off-state leakage is about 20nA and by the way, these parameters are not specified by all manufacturers.

The maximum collector current is internally limited by design, thereby removing any restrictions on capacitor size due to peak pulse-current discharge.

In certain applications, this open collector output can be used as an auxiliary output terminal, with current-sinking capability similar to the output (pin 3).

TOP ↑

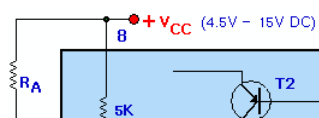

Pin 8 (Vcc +ve):

The V+ pin (also referred to as Vcc) is the positive supply voltage terminal of the NE-555 timer IC. Supply-voltage operating range for the NE-555 is +4.5 volts (minimum) to +16 volts (maximum), and it is specified for operation between +5 volts and +15 volts. The device will operate essentially the same over this range of voltages without change in timing period. Actually, the most significant operational difference is the output drive capability, which increases for both current and voltage range as the supply voltage is increased. Sensitivity of time interval to supply voltage change is low, typically 0.1% per volt. There are special and "MIL-SPEC" military devices available that operate at voltages as high as 18 volts.

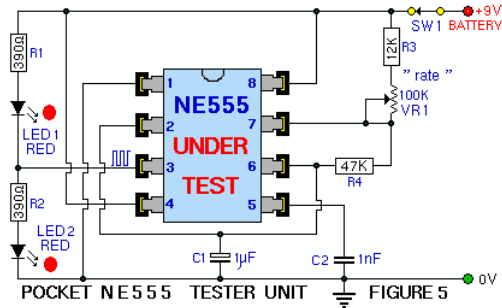

Build yourself a simple NE-555 test circuit of Figure 5 (above) to get you going and test all your NE-555 timer ic's. You can instantly check to see if they are functioning. Another use is as a NE-555 "trouble shooter" circuits. This tester will tell you if it's a goer. Make sure the NE-555 goes in the correct way as per the drawing. Otherwise, smoke may result.

TOP ↑

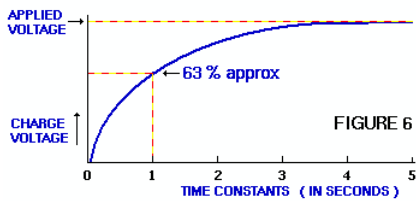

The capacitor charging slows down as it nears its expected charge however, in actual fact it never reaches the full +Vcc supply voltage. Please note: This is the nature of the beast, remember this. That being the case, the maximum charge it receives in the timing circuit (66.6% of the supply voltage) which is a little over the charge received after a time constant (63.2%). ($Q = I \times t$)

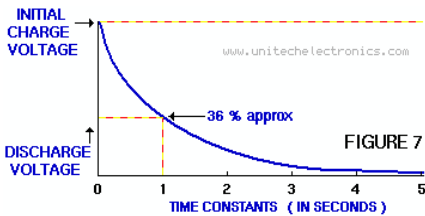

The capacitor discharges slowly down until it almost discharges fully, however they never quite reach the ground potential, this is also the nature of the beast. This means they always will be a minimum voltage present in a circuit it operates at greater than zero. The Timing circuit is about 63.2% of the supply voltage.

TOP ↑

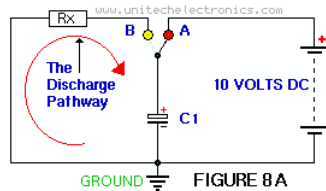

The discharge time (t) of a capacitor to discharge exponentially to theoretical zero also takes time and this can be shortened by decreasing resistance (R) to the flow of current. ($t = R \times C$)

Basic NE-555 Operating Modes:

The NE-555 timer has two basic operational modes: one shot and astable. In the one-shot mode, the NE-555 acts like a monostable multivibrator. A monostable is said to have a single stable state and that is the "off" state. Whenever it is triggered by an input pulse, the monostable switches to its temporary state. It remains in that state for a period of time determined by an R-C network. It then returns to its stable state.

In other words, the monostable circuit generates a single pulse of a fixed time duration each time it receives an input trigger pulse. Thus the name one-shot. One-shot multivibrators are used for turning some circuit or external component on or off for a specific length of time. It is also used to generate delays. When multiple one-shots are cascaded, a variety of sequential timing pulses can be generated. Those pulses will allow you to time and sequence a number of related operations.

TOP ↑

The other basic operational mode of the NE-555 is as an astable multivibrator. An astable multivibrator is simply an oscillator. The astable multivibrator generates a continuous stream of rectangular on-off pulses that switch between two voltage levels. The frequency of the pulses and their duty cycle are dependent upon the R-C network values.

Basic NE-555 One-Shot Operation:

Fig. 4 shows the basic circuit of the NE-555 connected as a monostable multivibrator. An external RC network is connected between the supply voltage and ground. The junction of the resistor and capacitor is connected to the threshold input which is the input to the upper comparator.

The internal discharge transistor is also connected to the junction of the resistor and the capacitor. An input trigger pulse is applied to the trigger input, which is the input to the lower comparator.

With that circuit configuration, the control flip-flop is initially reset. Therefore, the output voltage is near zero volts. The signal from the control flip-flop causes T1 to conduct and act as a short circuit across the external capacitor. For that reason, the capacitor cannot charge. During that time, the input to the upper comparator is near zero volts causing the comparator output to keep the control flip-flop reset.

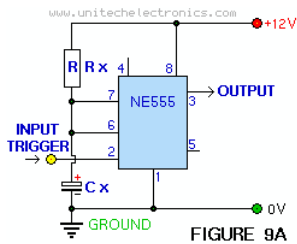

Notice how the monostable continues to output its pulse to pin 3 regardless of the inputs "swing" back up. The reason for this is because the output is **only** triggered by the input pulse, the output actually depends on the capacitor charge **CX**.

TOP ↑

Basic NE-555 Monostable Mode:

The NE-555 in fig. 9a is shown here in its most basic mode of operation as a triggered monostable. One immediate observation is the extreme simplicity of this circuit. Only two components to make up a timer, a capacitor and a resistor. And for noise immunity maybe a capacitor on pin 5.

Due to the internal latching mechanism of the NE-555, the timer will always time-out once triggered, regardless of any subsequent noise (such as bounce) on the input trigger (pin 2).

This is a great asset in interfacing the NE-555 with noisy sources.

Just in case you don't know what **'bounce'** is: bounce is a type of fast, short term noise caused by a switch, relay, etc. and then picked up by the input pin.

TOP ↑

The trigger input is initially high (about 1/3 of +V). When a negative-going trigger pulse is applied to the trigger input (see fig. 9a), the threshold on the lower comparator is exceeded. The lower comparator, therefore, sets the flip-flop. That causes T1 to cut off, acting as an open circuit. The setting of the flip-flop also causes a positive-going output level which is the beginning of the output timing pulse.

The capacitor now begins to charge through the external resistor. As soon as the charge on the capacitor equal 2/3 of the supply voltage, the upper comparator triggers and resets the control flip-flop. That terminates the output pulse which switches back to zero. At this time, T1 again conducts thereby discharging the capacitor. If a negative-going pulse is applied to the reset input while the output pulse is high, it will be terminated immediately as that pulse will reset the flip-flop.

Whenever a trigger pulse is applied to the input, the NE-555 will generate its single-duration output pulse. Depending upon the values of external resistance and capacitance used, the output timing pulse may be adjusted from approximately one millisecond to as high as on hundred seconds. For time intervals less than approximately 1-millisecond, it is recommended that standard logic one-shots designed for narrow pulses be used instead of a NE-555 timer. IC timers are normally used where long output pulses are required. In this application, the duration of the output pulse in seconds is approximately equal to:

TOP ↑

$$T = 1.1 \times R \times C \text{ (in seconds)}$$

The output pulse width is defined by the above formula and with relatively few restrictions, timing components R(t) and C(t) can have a wide range of values. There is actually no theoretical upper limit on T (output pulse width), only practical ones.

The lower limit is 10uS. You may consider the range of T to be 10uS to infinity, bounded only by R and C limits. Special R(t) and C(t) techniques allow for timing periods of days, weeks, and even months if so desired.

However, a reasonable lower limit for R(t) is in the order of about 10Kilo ohm, mainly from the standpoint of power economy. (Although R(t) can be lower than 10K without harm, there is no need for this from the standpoint of achieving a short pulse width.) A practical minimum for C(t) is about 95pF; below this the stray effects of capacitance become noticeable, limiting accuracy and predictability. Since it is obvious that the product of these two minimums yields a T that is less than 10uS, there is much flexibility in the selection of R(t) and C(t). Usually C(t) is selected first to minimize size (and expense); then R(t) is chosen.

The upper limit for R(t) is in the order of about 15 Mega ohm but should be less than this if all the accuracy of which the NE-555 is capable is to be achieved.

[TOP ↑](#)

The absolute upper limit of R(t) is determined by the threshold current plus the discharge leakage when the operating voltage is +5 volt. For example, with a threshold plus leakage current of 120nA, this gives a maximum value of 14M for R(t) (A very optimistic value). Also, if the C(t) leakage current is such that the sum of the threshold current and the leakage current is in excess of 120 nA the circuit will never time-out because the upper threshold voltage will not be reached.

Therefore, it is good practice to select a value for R(t) so that, with a voltage drop of 1/3 V+ across it, the value should be 100 times more, if practical.

So, it should be obvious that the real limit to be placed on C(t) is its leakage, not its capacitance value, since larger-value capacitors have higher leakages as a fact of life. Low-leakage types, like tantalum or NPO, are available and preferred for long timing periods.

Sometimes input trigger source conditions can exist that will necessitate some type of signal conditioning to ensure compatibility with the triggering requirements of the NE-555.

This can be achieved by adding another capacitor, one or two resistors and a small signal diode to the input to form a pulse differentiator to shorten the input trigger pulse to a width less than 10uS (in general, less than T). Their values and criterion are not critical; the main one is that the width of the resulting differentiated pulse (after C) should be less than the desired output pulse for the period of time it is below the 1/3 V+ trigger level.

[TOP ↑](#)

There are several different types of NE-555 timers manufactured today. The LM-555 from National is the most common one these days, in our opinion. The Exar XR-L555 timer is a micropower version of the standard NE-555 offering a direct, pin-for-pin compatible substitute device with an advantage of a lower power operation making it ideal for battery and other portable applications etc.

It is capable of operation of a wider range of positive supply voltage from as low as 2.7volt minimum up to 18 volts maximum. At a supply voltage of +5V, the L555 will typically dissipate of about 900 microwatts, making it ideally suitable for battery operated circuits. The internal schematic of the L555 is very much similar to the standard NE-555 but with additional features like 'current spiking' filtering, lower output drive capability, higher nodal impedances, and better noise reduction system.

See at [Maxim's ICM7555](#), and also at [Sanyo's website](#) LC7555 models are a low-power, general purpose CMOS design version of the standard NE-555, also with a direct pin-for-pin compatibility with the regular NE-555. Its main advantages are very low timing / bias currents, low power-dissipation operation and an even wider voltage supply range of as low as 2.0 volts to 18 volts.

At 5 volts the 7555 will dissipate about 400 microwatts, making it also highly suitable for battery operation. The internal schematic of the 7555 (not shown) is however totally different from the normal NE-555 version because of the different design process with cmos technology. It has much higher input impedances than the standard bipolar transistors used. The cmos version removes essentially any timing component restraints related to timer bias currents, allowing resistances as high as practical to be used.

This very versatile version should be considered where a wide range of timing is desired, as well as low power operation and low current sync'ing appears to be important in the particular design.

[TOP ↑](#)

A couple years after Intersil, [Texas Instruments](#) came on the market with another cmos variation called the LINCMOS (LINear CMOS) or Turbo 555.

In general, different manufacturers for the cmos 555's reduced the current from 10mA to 100uA while the supply voltage minimum was reduced to about 2 volts, making it highly ideal type for 3 Volt applications. The CMOS version is the choice for battery powered circuits, however, on the negative notes side for the CMOS 555's is the reduced output current, both for sync and source, This is not really a problem as a FET or a NPN or PNP transistor can be added as an amplifier or a heavier switching output device if so required. For a simple comparison, the regular NE-555 can easily deliver a 200mA output versus between 5mA to 50mA for the 7555. On the work test bench the regular NE-555 reached a limited output frequency of 180Khz while the 7555 easily surpassed the 1.1Mhz mark and the TLC555 ceased at about 2.4Mhz. Components used were 1% metal film Resistors and quality low-leakage capacitors, supply voltage used was 10volt DC regulated

Some of the less desirable properties of the regular NE-555 are high supply current, high trigger current, double output transitions, and inability to run with very low supply voltages. These problems have been remedied in a collection of CMOS successors.

A word of caution about the regular NE-555 timer chips; the NE-555, along with some other timer ic's, generates a huge (approx 150mA) supply current glitch during each

output transition. Be very sure to use a hefty bypass capacitor over the power connections near the timer chip. And even so, the NE-555 may have a tendency to generate double output transitions.

[TOP ↑](#)

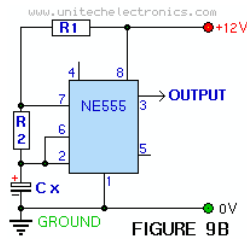

Basic NE-555 Astable operation:

Figure 9b shows the NE-555 connected as an astable multivibrator. Both the trigger and threshold inputs (pins 2 and 6) to the two comparators are connected together and to the external capacitor. The capacitor charges toward the supply voltage through the two resistors, R1 and R2. The discharge pin (7) connected to the internal transistor is connected to the junction of those two resistors.

When power is first applied to the circuit, the capacitor will be uncharged, therefore, both the trigger and threshold inputs will be near zero volts (see Fig. 10). The lower comparator sets the control flip-flop causing the output to switch high. That also turns off transistor T1. That allows the capacitor to begin charging through R1 and R2. As soon as the charge on the capacitor reaches 2/3 of the supply voltage, the upper comparator will trigger causing the flip-flop to reset.

That causes the output to switch low.

Transistor T1 also conducts.

The effect of T1 conducting causes resistor R2 to be connected across the external capacitor. Resistor R2 is effectively connected to ground through internal transistor T1. The result of that is that the capacitor now begins to discharge through R2.

[TOP ↑](#)

The only major differences between the single NE-555, dual 556, and quad 558 (incidentally both are 14-pin types), is the common power rail. For the other remaining pins, everything remains the same as the single version, 8-pin NE-555.

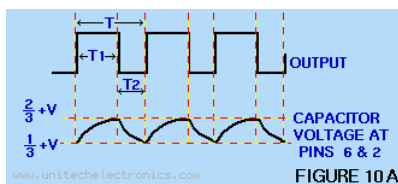

As soon as the voltage across the capacitor reaches 1/3 of the supply voltage, the lower comparator is triggered.

That again causes the control flip-flop to set and the output to go high.

Transistor T1 cuts off and again the capacitor begins to charge.

That cycle continues to repeat with the capacitor alternately charging and discharging, as the comparators cause the flip-flop to be repeatedly set and reset.

The resulting output is a continuous stream of nice clean rectangular pulses.

The frequency of operation of the astable circuit is dependent upon the values of R1, R2, and C. The frequency can be calculated with the formula:

[TOP ↑](#)

$$f = 1 / (.693 \times C \times (R1 + 2 \times R2))$$

The Frequency f is in Hz, R1 and R2 are in ohms, and C is in farads.

The time duration between pulses is known as the 'period', and usually designated with a 't'.

The pulse is on for t1 seconds, then off for t2 seconds.

The total period (t) is t1 + t2 (see fig. 10).

That time interval is related to the frequency by the familiar relationship:

$$f = 1/t \text{ or } t = 1/f$$

The time intervals for the on and off portions of the output depend upon the values of R1 and R2. The ratio of the time duration when the output pulse is high to the total period is known as the duty-cycle. The duty-cycle can be calculated with the formula:

$$D = t1/t = (R1 + R2) / (R1 + 2R2)$$

You can calculate t1 and t2 times with the formulas below:

$$t1 = .693(R1+R2)C$$

$$t2 = .693 \times R2 \times C$$

The NE-555, when connected as shown in Fig. 9b, can produce duty-cycles in the range of approximately 55 to 95%. A duty-cycle of 80% means that the output pulse is on or high for 80% of the total period. The duty-cycle can be adjusted by varying the values of R1 and R2.

Basic NE-555 Applications:

There are literally thousands, maybe 10's of thousands of individually unique ways that the ubiquitous NE-555 can be used in any or all electronic circuits. In almost every case, however, the basic circuit is either a one-shot or an astable. The application usually requires a specific pulse time duration, operation frequency, and duty-cycle. Additional components may have to be connected to the NE-555 to interface the device to external circuits or devices. In the remainder of this experiment, you will build both the one-shot and astable circuits and learn about some of the different kinds of applications that can be implemented.

[TOP ↑](#)

Basic simple NE-555 Free sample Circuits:

We have added-in a range of NE-555 circuit samples below for your perusal. Please experiment with them and have fun, electronics should be fun for everyone. Try (within reason) different component values and use the formulas mentioned earlier to calculate your final results. Make small changes, not large changes.

The most important thing to remember:

Note: For correct by-the-book monostable operation with the NE-555 timer, remember the "negative-going" trigger pulse width should be kept quite short when compared to the required output pulse width.

Values for the external timing resistor and capacitor can either be determined from the previous formulas. However, you should stay within the ranges of resistances shown earlier to avoid the use of large value electrolytic capacitors, since they tend to be leaky. Tantalum, low leakage electrolytics or mylar types should always be used.

For +Vcc supply noise "immunity" on most timer circuits we recommend a simple addition of a ceramic 0.01uF (10nF) capacitor between pin 5 and ground. In all circuit diagrams below we have used the LM555CN timer IC from National Semiconductor, but the NE555 and others should not give you any problems.

Now, please bare in mind, the noise on the supply line that is created by a NE-555 operating. It is always good practice to place fairly large value capacitors, say 470uF 16V or 1000uF 16 V when using the NE-555 as we have noted the spurious "dirty" harmonics from most NE-555 chips.

[TOP ↑](#)

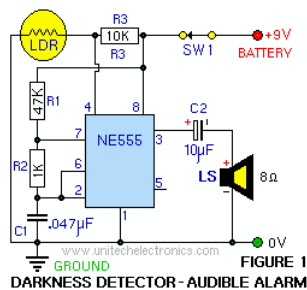

Darkness Detector: Figure 1 (above)

This is indeed an interesting circuit which has the facility to sound an alarm if it suddenly gets too dark compared to the previous light level. A simple use for this circuit would be its use to notify someone when a globe (or light bulb) fails to operate or is open circuit.

The darkness detector uses a regular cadmium-sulphide LDR (Light Dependent Resistor) to sense the "quick" absence of light falling on the LDR and to operate a small and quite cheap 8 ohm speaker. The LDR enables the alarm when light falls below a certain level. Calibration could be effective if a 47k potentiometer was added in series with the LDR.

[TOP ↑](#)

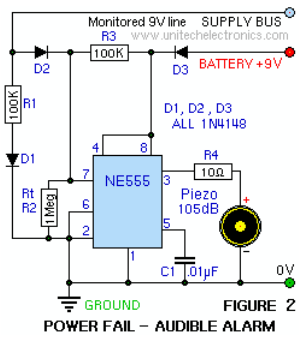

Power Failure Alarm: Figure 2 (above)

This circuit can be used as a simple yet effective audible 'Power-Failure Alarm'. In this cunning application it uses the NE-555 timer as an oscillator biased **off** by the presence of line-based DC voltage at Pin 7.

When the line voltage fails (monitored 9V line), the bias is removed, and the alarm tone will be heard in the piezo-electric speaker. Choose a Piezo around the 105dB mark.

R1 and C1 provide the DC bias that charges capacitor C1 to over 2/3 Vcc voltage, in this case, about 6.0 V thereby holding the timer output low. Diode D1(1N4148 / IN914) provides DC bias (approx 5.4V) to the timer-supply pin and optionally float-charges a rechargeable nickel metal hydride 9 volt battery across D2. R4 10 ohms is optional if needed. When the line power fails, the 9V input via D3, DC is applied to the timer through D2, resulting in a very audible sound. Experimentation with higher voltages such as 12V DC can result in some novel and some educational concepts coming to fruition.

[TOP ↑](#)

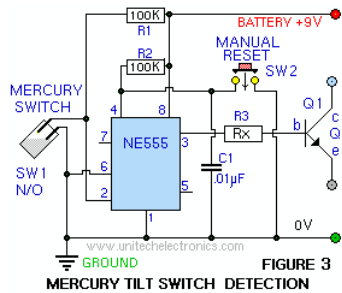

Fig. 3 Tilt Switch: Figure 3 (above)

This clever NE-555 application is basically an alarm circuit, it displays how to use a NE-555 timer and a simple small glass mercury switch to indicate an alarm condition, either by forced movement or by the act of tilting a protected item. As far as we know, there is no other metal which is a liquid at room temperature. Mercury is such a metal and has some unusual and unique properties which are diametrically opposed to the properties of water surface tension and side adhesion.

The mercury switch is carefully inserted into a short 20mm tube of plastic then mounted in its normally 'open' position, in which this allows the NE-555 timer's "trigger" pin 2 to stay high being fed via R1 100K.

Pin 3 output will stay low, as established by C1 0.1uF on startup acting upon pin 4. When the mercury switch is disturbed via vibration or movement thus causing its contacts to be bridged momentarily by the liquid mercury, the NE-555 latch is set to a high output level where it will stay even if the switch is returned to its starting position thus driving the base of Q1 via Rx (R3) which may be as low as 560 Ohms.

The high output can be used to enable an alarm of the visual or the audible type. Reset switch SW2 will silence the alarm and reset the latch. Due to the required characteristics of the Vcc +ve turn on, C1 must be ceramic 0.1uF (100 nF) capacitor.

[TOP ↑](#)

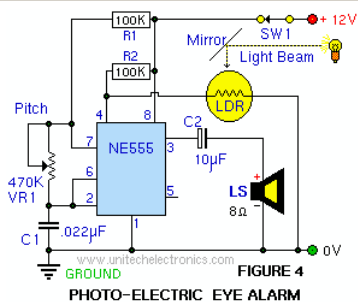

Photo-Electric Eye Alarm: Figure 4 (above)

The Photo-Electric Eye Alarm is similar circuit like the Darkness Detector of Figure 1. The same type of Photo-LDR (light dependent resistor) is employed as in Figure 1. The pitch tone for the speaker can be set and adjusted with the 470K ohm potentiometer. One of the great ideas here, is to send a beam of light via a tube approximately 30 cm long

with a standard 5 watt bulb (or similar) across a doorway or even a room and use this beam of light as an alarm, so, when the beam is broken, the NE-555 provides an audible indication of a "intrusion". This is similar to LED based systems currently in use today.

[TOP ↑](#)

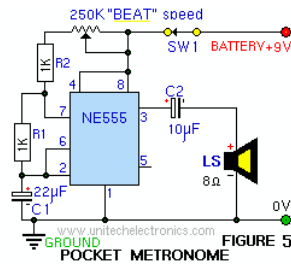

FIGURE 5

POCKET METRONOME

The Pocket Metronome: Figure 5 (above)

A Metronome is a widely used device in the entertainment and music industry. With a rhythmic 'toc-toc' sound you can set the tempo of a piece of music to the correct beats per minute, the speed of which can be adjusted with the VR1 250K potentiometer. R1 and R2 form the 50% duty cycle. A metronome is also a very handy tool if you learning to play music on an instrument and need to maintain the correct rhythm. It can be made to fit in a small "Jiffy Box" and as it is powered by a 9 Volt battery, the size can be reduced to whatever compact size you need. A volume control could be added, but only if required.

[TOP ↑](#)

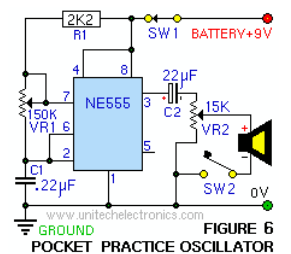

FIGURE 6

POCKET PRACTICE OSCILLATOR

C-W Practice Oscillator: Figure 6 (above)

C-W is the abbreviation for **Continuous Wave** or simply Morse-Code. You can utilise this neat circuit to practice the morse-code with this circuit, perhaps to get your amateur (ham) radio license . The VR1 150K potentiometer is for the 'pitch' and the 15K is to adjust the speaker's volume. The "Key" SW2 is a standard morse code key, these are available in most good electronics shops.

[TOP ↑](#)

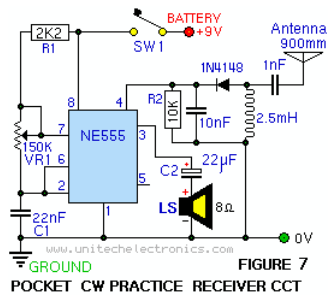

FIGURE 7

POCKET CW PRACTICE RECEIVER CCT

C-W Monitor: Figure 7 (above)

This ingenious little NE-555 circuit monitors the morse code 'on-air' via the "tuned circuit" connected to pin 4 and the short wire 900mm antenna. The 100K potmeter controls the tone-pitch. It is open to a small amount of experimentation for the end user to achieve the best results.

[TOP ↑](#)

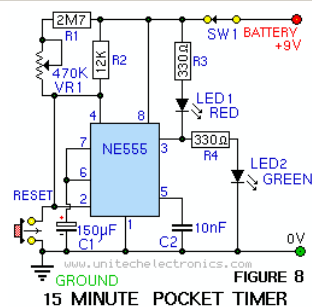

FIGURE 8

15 MINUTE POCKET TIMER

10 -15 Minute Timer: Figure 8 (above)

This neat little circuit can be used as a time-out warning for Ham Radio operators. The Australian Communications Commission (ACC) requires that a Amateur Radio (HAM) operator identify his or her station by giving his or her call-sign at least every 10 minutes, basically operating under the same rules that govern commercial AM and FM radio stations.

This can present itself as a small challenge, especially when carrying on lengthy intense conversations resulting in one actually loosing all track of time while "chatting".

The NE-555 comes to the rescue in this simple circuits and is used as a one-shot so that a visual warning indicator becomes active after 10-minutes.

It can be further cascaded to a second NE-555 that is setup as a simple "beep" oscillator as in FIGURE 6A .At the commencement of conversation, remember to the reset switch SW1 which will causes the **Green** led to light up.

Operation is simple:
After 10 minutes, set by the 470K potentiometer VR1, the 'Red' led will light to warn the operator that heor she must identify and , if the circuit in FIGURE 6A is implemented, a short "beep" will assist in sticking to the ACC rules. Using a trusty digital stop watch , adjust VR1 to indicate 10 minutes or as close to it as you can.

[TOP ↑](#)

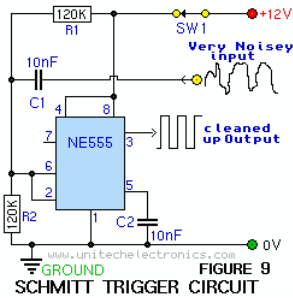

FIGURE 9
SCHMITT TRIGGER CIRCUIT

Schmitt Trigger: Figure 9 (above)

A very simple, but highly effective circuit. In this circuit, the NE-555 cleans up all noise on the input signal resulting in a nice clean and "squared signal" output. Results are immediately realised when used in radio control (R / C), as it will clean up noisy servo signals caused by "RF" interference induced by long servo leads. As long as **R1 equals R2**, the NE-555 will automatically be biased for any supply voltage in the 5 to 15 volt (maximum 16V)range. Please note, that there is a 180-degree phase shift.
This circuit also lends itself to condition 50Hz or 60-Hz sine-wave reference signal taken from a 6.3 volt AC transformer before driving a series of binary or divide-by-N counters.
The major advantages are that unlike a typical conventional multivibrator type of squares which divides the input frequency by 2, this method simply squares the 50Hz or 60-Hz sine wave reference signal without any division what so ever.

[TOP ↑](#)

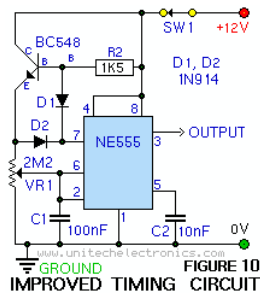
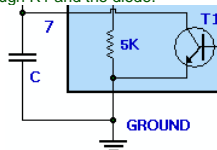

FIGURE 10
IMPROVED TIMING CIRCUIT

Improved Timing Circuit: Figure 10 (above)

Much more improved stable timing output is achieved with the addition of a single transistor and a diode to the R-C timing network.
The frequency can actually be varied over a wide range while maintaining a constant 50% duty-cycle. When the output Pin 3 is **HIGH**, the transistor is biased into saturation by R2 so that the charging current passes through the transistor and R1 to C. When the output goes **LOW**, the discharge transistor (pin 7) cuts off the transistor and discharges the capacitor through R1 and the diode.



The high & low periods are equal. The value of the capacitor (C) is 100nF (0.1uF) and the resistor "VR1 Potentiometer" is 2M2 (2.2 Meg Ohms).
This is but a mere example of how to configure it , R - C values are entirely dependant on the type of application, so choose your own values (within reason). The diode can be any generic small signal diode, for example the 1N4148, or 1N914 can be ideally used however, a high conductance Germanium or Schottky type of diode will minimize the diode voltage drops in the transistor and diode. (only if that is absolutely necessary for operation)
Having said that, the transistor should have a **high beta**(gain) so that the R2 1K5 can be larger and still cause the transistor to saturate. The transistor can be a BC547, BC548, BC549,

2N2222 or similar gain NPNs.

TOP ↑

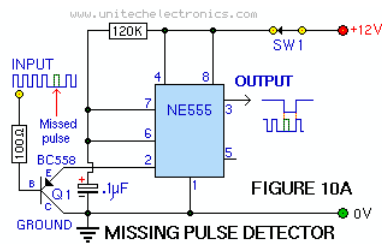

This particular circuit is a "one-shot" triggered device that is continually retriggered by incoming pulses to the base of Q1 BC558. A missing pulse is all that is required to prevent the "re-triggering" pulse before the timing cycle is completed, hence causing PIN 3 output to go LOW until a fresh input pulse arrives at the base of Q1. R1 and C1 form the control and response time. Excellent to utilise in security alarm circuits, continuity testers, and cable testing.

Missing Pulse Detector (A basic simple circuit): Figure 10A (above)

This transistor can be replaced with a BC547, BC549 or 2N2222. This is a very basic example but does in fact work. Try some small experimentation with the values of R and C. **Be aware that 100 ohms is not the preferred value for R1**, it was placed there for a small incoming signal from a remote control over several hundreds of meters away and the filtering required for that length of cable has deliberately been left out for simplicity's sake. The correct value if driven from another source would be determined by the amount of current and voltage applied to almost saturate the base of Q1 BC548 thus turning it "on" so in theory, R1 (presently represented as 100 ohms could be 1K or 2K2 or higher) it is of your own choice.

Briefly, if there is a missing "pulse" to the base input of Q1 BC548 or no signal at all, it sees it as a missing pulse inverts the signal within the NE-555 and sounds a piezo DC buzzer.

TOP ↑

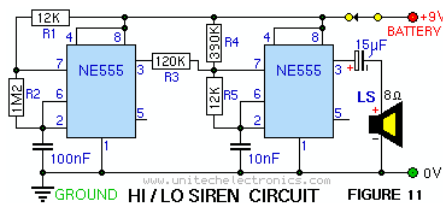

Hi /Lo or Hee-Haw Tones: FIGURE 11 (above)

This circuit runs two NE-555 timers together to create a "Hi / Lo" tone slightly similar to a "Hee-Haw" tone. One sets the markspace ratio of on/off from its Pin 3 output. The second 555 forms a simple oscillator, you can add this great effect for your childrens toys.

TOP ↑

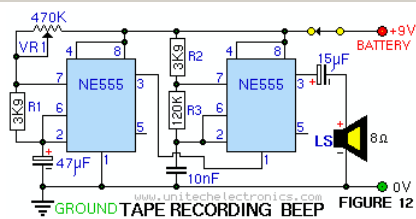

Recording Beep: FIGURE 12 (above)

As you may be aware, it is actually **highly illegal** to record any phone conversation without the "other party's" full permission. This circuit is used to keep recording of telephone conversations within the guidelines of being legal.

Once you have secured the "other party's" permission to record their conversation, then this circuit device built in a box is what you will need to have on "standby" the unit "beeps" every 10 seconds. This will not require interfacing nor connecting to the phone lines as it is a stand-alone 9V unit which fits snugly within a "Jiffy-Box" (see "Jaycar" or "Altronics").

The output of left IC1 Pin 3 is fed to Pin 1 of the right side NE-555, supplying a ground pin momentarily. This drives the NE-555 to produce a higher tone while on the high side of the left NE-555's "ON" cycle. The output from the right side (2nd) NE-555's pin 3 feeds a signal via C3 15μF to the 8 ohm speaker. Any el-cheapo 8-ohm speaker will do.

TOP ↑

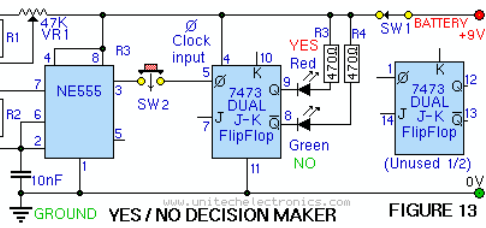

Electronic Decision Maker circuit. Figure 13 (above)

Basically it's a **Yes** or **No** decision maker for use when you can't make up your mind yourself, to have a bit of fun with. The NE-555 is wired as a Astable Oscillator, driving in turn, via pin 3, the **7473** Dual J - K flip-flop.

When you press S1 it randomly selects the 'YES' or 'NO' led. The leds flashrate is about 2KHz (kilo-Hertz), which is much faster than your eyes can follow, so initially it appears that both leds are 'ON'. As soon as the switch is released only one led will be lit.

[TOP ↑](#)

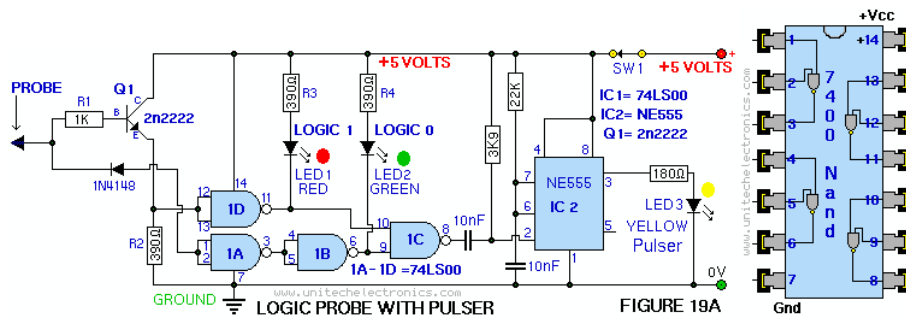

Basic NE-555 based Logic Probe: Figure 14 (above)

This logic Probe provides you with three visible indicators;

- "Logic 1" (+, red led),
- "Logic 0" (-, green led),
- and "Pulse" (yellow led).

The basic circuit as it is shown is very good for TTL and CMOS.

The yellow or 'pulse' led comes on for approximately 200 mSec to indicate a pulse without regards to its width. This feature enables one to observe a short-duration pulse that would otherwise not be seen on the logic 1 and 0 led's.

A small switch (subminiature slide or momentary push) across the 20K resistor can be used to keep this "pulse" led on permanently after a pulse occurs.

In operation, for a logic 0 input signal, both the '0' led and the pulse led will come 'ON', but the 'pulse' led will go off after 200 mSec. The logic levels are detected via resistor R1 (1K), then amplified by T1 (NPN, Si-AF Pre-amplifier/Driver), and selected by the 7400 IC for what they are. Diode D1 is a small signal diode to protect the 74LS7400 and the leds from excessive inverse voltages during capacitor discharge.

For a logic '1' input, only the logic '1' led (red) will be 'ON'. With the switch closed, the circuit will indicate whether a negative-going or positive-going pulse has occurred. If the pulse is positive-going, both the '0' and 'pulse' led's will be on. If the pulse is negative-going, the '1' and 'pulse' led's will be on.

[TOP ↑](#)

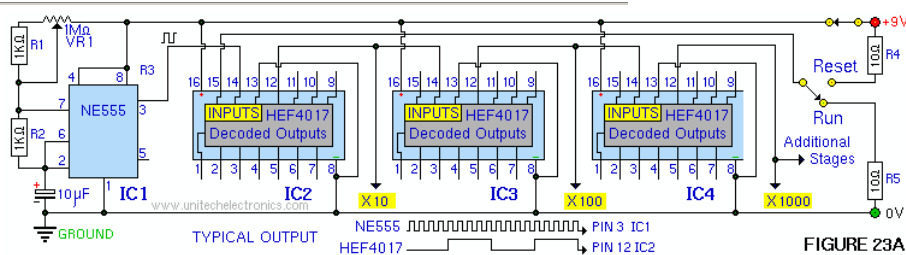

Basic NE-555 based Extended timer: Figure 23A (above)

VR1 together with R1 control the pulse rate from the NE-555, C1 10uF set the timing. Output from Pin 3 of IC 1 NE-555 travels to the clock input of IC2, HEF4017. Please note: On IC2, IC3 and on IC4 pin12 is an output referred to as "carry Enable". The resultant timing is, from IC1, 10's, from IC2 100's and from IC 4 1000's in delays. The 4017 sequentially makes 1-of-10 outputs high while others stay in a "low" state in response to inward clock pulses. Many applications count on the 4017. The actual counting occurs when pin 13 and 15 are low logic level. Switch SW1 is used to reset or active and run the timers.

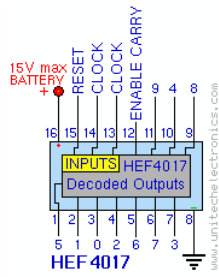

The Basic NE-555 Circuits :

Have fun with electronics with different sounding devices, different indicating devices such as lights, LEDs, noise making devices, relays. Try different types of LDR's and...remember, if for some reason you get false triggering, connect a ceramic 0.01uF (=10nF) capacitor between pin 5 (NE-555) and ground. In all circuit diagrams below I used the LM555CN timer IC from National. The NE-555 timer will work with any voltage between 3.5 and 15volt. A single 9-volt Alkaline battery is usually a good general choice.

[TOP ↑](#)

The Basic NE-555 NEON LAMP DRIVER Circuit :

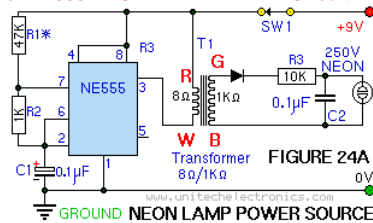

A simple circuit to power a NEON lamp. Primarily used to test neons where safety is a requirement. The R1 - R2 - C1 circuit determines the NE-555 to oscillate producing a voltage at Pin 3 driving the small 8 ohm transformer's primary windings, the secondary windings are 1K ohms. This results in a ratio of 125 times gain, however we all know that's not going to fly. Losses ?? The theoretical voltage of 500 Volts AC passing through R3 10K dropping to around 180V AC thus striking the gas within the neon and lighting it. This circuit was designed for pocket use.

[TOP ↑](#)

The Basic NE-555 Infra-Red Transmitter Circuit :

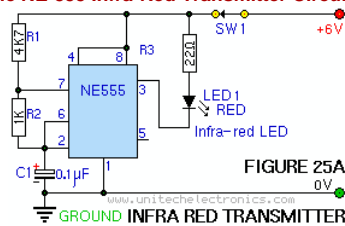

A simple NE-555 circuit to primarily power infra-red LEDs. L555 may also be used. The R1 - R2 - C1 circuit determines the NE-555 to oscillate producing a voltage at Pin 3 driving the infra-Red LED , being fed +Vcc via R3 22 ohms. This simple NE-555 circuit runs on +6V DC. This circuit was designed for security use where inconspicuous infra-red LED beams were needed.

[TOP ↑](#)

The Basic NE-555 Simple Flasher Circuit :

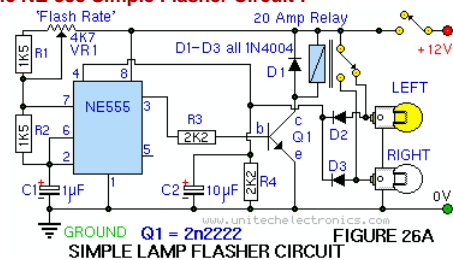

A simple NE-555 dual globe flasher circuit to primarily power a relay that switches power to each globe in turn.. The R1 - R2 - C1 along with VR1 4K7 combo determines the NE-555 to oscillate slowly producing a voltage at Pin 3 driving the base of Q1 2N2222 an NPN transistor, which in turn drives the relay that switches the two globes on and off. Diodes D2 and D3 provide the feedback logic 1 pulse to Pin 4 reset of the 555. C2 forms a slight "buffering" function. This simple NE-555 circuit runs on +12V DC, the circuit is protected against back emf by D1.
Applications: This circuit was designed for Security use or Vehicle breakdown dual lamp use where needed.

The Basic NE-555 Improved Oscillator Circuit :

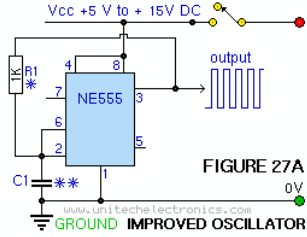

FIGURE 27A

GROUND IMPROVED OSCILLATOR

A simple NE-555 circuit with a vastly improved oscillation. It uses only one resistor and one capacitor. For the purpose of the simplicity in display, we have left off the 0.01uF ceramic capacitor which we would usually connect to pin 5. The circuit draw little current from the supply, however the frequency of operation will in fact be lower than a dual resistor circuit as describe in many other circuits.

This lower frequency is mostly due to the fact that the voltage delivered by the output line from Pin 3 is 1.7Volts less than the supply rails. The output is still capable of driving up to 200mA. Don't exceed this. The R1 x C1 circuit determines the NE-555 to oscillate producing a voltage at Pin 3 which also is fed back via R1 1K driving the NE-555 chip into almost perfect oscillation. See it on the CRO . This simple NE-555 circuit runs on +5V to +15V DC. Most circuits run very well at 15V DC all day. This circuit was designed to use for reasonably good square wave output formations.

[TOP ↑](#)

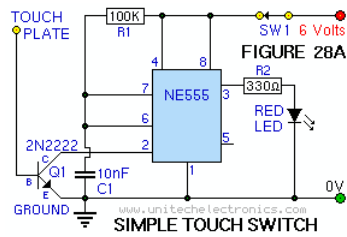

FIGURE 28A

GROUND SIMPLE TOUCH SWITCH

The Basic NE-555 SIMPLE TOUCH SWITCH :

This simple application of the NE-555 is "triggered" on pin 2 via Q1 2N2222 NPN transistor operating the NE-555 in Astable Mode. (see FIGURE 30A) The generated voltage is about 3 Volts less than the supply rail voltage due to Pin3 rising to approximately 1.7Volts below the supply rail voltage, add to this the 0.6V loss through the diode. It is sensitive enough to pick up stray voltages such as static electricity and induce mains radiation picked up by our bodies. It can be improved by the addition of a second pad connected to ground which will enhance its operation.

[TOP ↑](#)

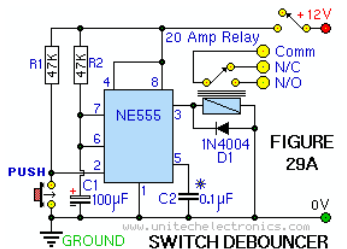

FIGURE 29A

GROUND SWITCH DEBOUNCER

The Basic NE-555 SIMPLE SWITCH DE-BOUNCER :

This mode of operation is also called MONOSTABLE MODE. The NE-555 can indeed be wired as a monostable. A monostable has one stable state and that is the OFF state. The "unstable" state is called the "ON" or "HIGH" LOGIC state. When Pin 2 is triggered by an input pulse, the monostable switches to its temporary or ON state. It remains in that state for a period of time determined by an R-C network and returns to its stable previous OFF state. Put simply, the monostable circuit generates a single fixed duration pulse during each time it receives its input trigger pulse.

The monostable circuit can also be called a "ONE-SHOT" due to the single-pulse created. This type of circuit can be used for many switching applications, activating an external device for a specific length of time. They can also be used to generate timed delays.

Another desirable use for this type of circuit is to take the brief pulse of a push-button and

activate a external device. We refer to this simply as a "PULSE-EXTENDER".

Another novel use is that it can also be used to clean-up the noisy output of a push-button due to poor contacts or a high moisture area, this we refer to as SWITCH DE-BOUNCING.

The simple diagram below shows a push-button (on left) connected to a NE-555. When this push-button is pressed, you will note that a relay has been added to Pin 3 (output) the relay operates for 5 seconds. The button must be released before the time-interval has expired otherwise the time is extended, so please note that this is a limitation of this simple circuit.

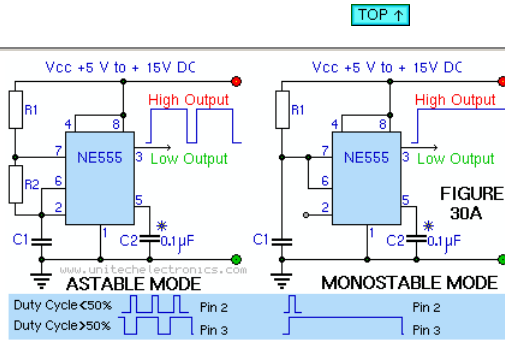

The Basic NE-555 ASTABLE and MONOSTABE MODES :

FIGURE 30A and also Figure 9b (above) both show the NE-555 connected as an astable multivibrator. Both the trigger and threshold inputs (pins 2 and 6) to the two comparators are connected together and to the external capacitor. The capacitor charges toward the supply voltage through the two resistors, R1 and R2. The discharge pin (7) connected to the internal transistor is connected to the junction of those two resistors.

When power is first applied to the circuit, the capacitor will be uncharged, therefore, both the trigger and threshold inputs will be near zero volts (see Fig. 10). The lower comparator sets the control flip-flop causing the output to switch high. That also turns off transistor T1. That allows the capacitor to begin charging through R1 and R2. As soon as the charge on the capacitor reaches 2/3 of the supply voltage, the upper comparator will trigger causing the flip-flop to reset.

That causes the output to switch low. Transistor T1 also conducts. The effect of T1 conducting causes resistor R2 to be connected across the external capacitor. Resistor R2 is effectively connected to ground through internal transistor T1. The result of that is that the capacitor now begins to discharge through R2.

INPUTS			OUTPUTS	
Pin 4 (LOW)	Pin 6 (HIGH)	Pin 2 (LOW)	Signetics NE555V	National LM555H
0	0	1	RESETS	RESETS
1	1	1	0	0
0	0	0	0	0
1	1	0	RESETS	RESETS
1	0	1	1	0
0	0	1	0	0
0	0	0	0	0
1	0	0	SETS	SETS
1	1	0	0	0
0	0	0	0	0
0	1	0	0	0

PIN 4 is RESET. PIN 2 is TRIGGER. PIN 6 is THRESHOLD.
PINS 2, 4 & 6 ARE CLASSED AS "ACTIVE"

TABLE 2

Check the listing in Table 2. It shows some variations in the NE-555 manufacturing process primarily by two different manufacturers, National Semiconductor and Signetics Corporation. Since there are many other NE-555 chip manufacturers we suggest when you build your prototype circuits first using one of these two brands and stick with the particular NE-555 model, you may wish to specify a certain brand in your own NE-555 "circuit" schematics. Unless you "really" know what you're doing of course...some do,.... some don't.

BIG NOTICE - READ NOW

The absolute "maximum" ratings (in free air) for NE/SA/SE types are:

- + Vcc, supply voltage: 18V Input voltage (CONT, RESET, THRES, TRIG): Vcc
- Output current: 225mA (approx)
- Operating free-air temp. range: NE555..... 0°C - 70°C
- SA555 :..... -40°C - 85°C
- SE555 :..... -55°C - 125°C
- SE555C :..... -55°C - 125°C
- Storage temperature range: -65°C - 150°C
- Case temperature for 60sec. (FK package): 260°C

NE-555 Timer - Frequency and Duty Cycle Calculator

555 Timer - Frequency and Duty Cycle Calculator

Enter values for Resistor R1, Resistor R2, and Capacitor C1 and press the calculate button to solve for positive time interval (T1) and negative time interval (T2).
 For example, a 12,000 ohm (12K) resistor (R1) and 150,000 ohm (150K) (R2) and 0.22 uF capacitor will produce output time intervals of **24.698** mS positive (T1) and **22.869** mS negative (T2).
 The frequency will be approximately **20.979 Hz**. Please Note: R1 should always be greater than 1K Ohms and C1 should be greater than 0.0005 uF.
 Scroll up this page for basic NE-555 information (pinouts & many interesting NE-555 circuits devised for your interest).

Positive Time Interval (T1) = 0.693 * (R1 + R2) * C

Negative Time Interval (T2) = 0.693 * R2 * C

Frequency = 1.44 / ((R1 + R2 + R2) * C)

R1 (K Ohms)	R2 (K Ohms)	C (Microfarads)	Calculate
<input type="text"/>	<input type="text"/>	<input type="text"/>	
T1 (Milliseconds)	T2 (Milliseconds)	Frequency (Kilohertz)	Reset
<input type="text"/>	<input type="text"/>	<input type="text"/>	

The Ubiquitous NE-555 Timer Calculator

Acknowledgement

Portions of this particular web page were extracted from our own private collection of circuits and experiments since 1979.

[← Go Back](#)

[TOP ↑](#)

[NEXT →](#)

Layout is Copyright © 1996 Unitech Electronics Pty. Ltd. ALL RIGHTS RESERVED.
 Last updated: January 28th 1996