

Sound Blaster Microphone Preamplifier

Copyright Tomi Engdahl 1997

Summary of circuit features

- Brief description of operation: Simple microphone preamplifier which enable using dynamic microphone with Sound Blaster card
- Circuit protection: No special protection circuits used
- Circuit complexity: Very simple one transistor circuit
- Circuit performance: Amplification 35 dB, flat frequency response from 20 Hz to 20 kHz, quite poor distortion performance figures, a little bit noisy
- Availability of components: Uses common and easily available components
- Design testing: Circuit is based basically on quite well tested my simple microphone preamplifier. I have built one prototype of this circuit and it worked nicely.
- Applications: Use dynamic microphone successfully with Sound Blaster soundcard
- Power supply: Uses +5V bias voltage from Sound Blaster microphone input
- Estimated component cost: Electronics components than \$10
- Safety considerations: No special electrical safety considerations.

Information about computer soundcard microphone inputs

Soundblaster soundcard series (SB16, SB32, AWE32 and AWE64) have all a microphone input designed to be used with the electret microphones which come with the soundcard package (some packages) or with separate microphone designed to be used with SoundBlaster soundcards (there are separate microphones and some monitors have built-in microphones like this).

Typical characteristics of Sound Blaster microphone input:

Input Type: Unbalanced Low Impedance

Input Sensitivity: Approx. -20dBV (100mV or 0.1Volt)

Input Impedance: 600 to 1500. (Ohms)

Input Connector: 3.5mm Miniplug (Stereo Jack)

Input Wiring: Audio on Tip, Ground on Sleeve, 5Volts DC Bias on Ring

Because the microphone input needs very high input levels it is not suitable to be used with any other microphone type than electret capsule microphones. If you connect a dynamic microphone (which gives typically few mV voltage) and try to record it you will get very low signal level with lots of noise.

The circuit to solve the problem

Dynamic microphones can be connected to SoundBlaster if a suitable microphone preamplifier is built which can amplify the signal levels from dynamic microphones so much that they give enough level for SoundBlaster. This amplification can be quite easily done using simple single transistor microphone preamplifier circuit:

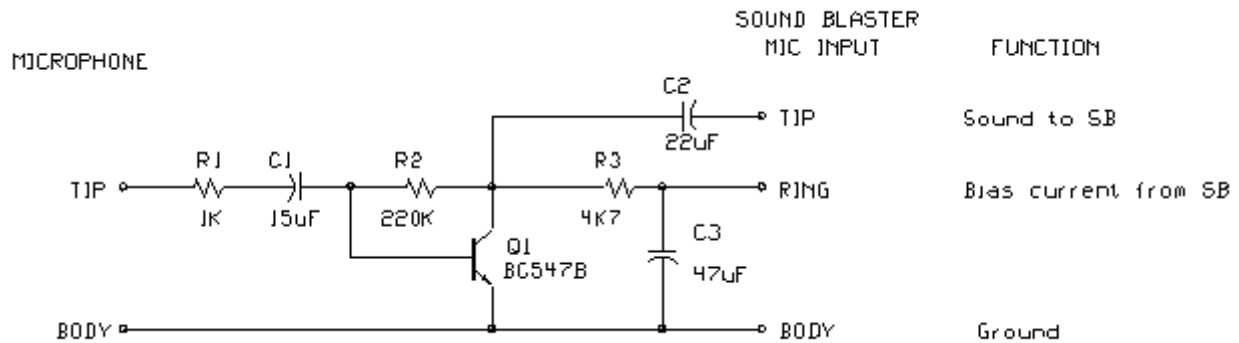

This circuit gives amplification of about 30-50 which is enough to make the signals from dynamic microphones enough high to be handled well by SoundBlaster. The circuit is very simple so the amplification is not accurately defined (depends on transistor parameters which can vary from transistor to transistor) and other performance figures are not the best possible. The circuit has a very nice feature that it does not need any external power supply because it uses the bias voltage (+5V) which SoundBlaster sends normally to the electric microphone as it's power source. I have used this circuit successfully with AKG D 60 S dynamic microphone and Sound Blaster 16.

Using this circuit you can add better microphones than those cheap multimedia microphones to your soundcards quite easily. With all SoundBlasters a better microphone is not yet a guarantee for better sound quality because the poor frequency response of the microphone preamplifier in SB16 cards. If you want even better sound quality you might consider building by [simple microphone preamplifier](#) design and connect it to the line level input of your SoundBlaster.

Component list

R1 1 kohm
 R2 220 kohm
 R3 4.7 kohm
 C1 15 uF 10V electrolytic (you use 10 uF or 22 uF if you can't find 15 uF easily)
 C2 22 uF 10V electrolytic
 C3 47 uF 10V electrolytic
 Q1 BC547B

Other parts needed: 3.5 mm stereo plug and connector for the microphone.