

Universal Preamp / Mixer

Rod Elliott (ESP)

Introduction

I have had a great many enquiries about small mixers, and this project should suit the needs of anyone who needs a very basic mixing unit. It has an input buffer, tone controls, and a 4 input mixing amplifier. I have called it "universal" since the same PCB can be used for many applications requiring basic amplifier modules. It can be used as a hi-fi preamp, mixer, general purpose amplifier/ tone control building block, or you may find other applications just waiting for something like this.

The list of configurations possible is so broad as to make it difficult to cover them all. The secure site shows several configurations for the PCB, from the basic functionality described, right through to using it as a balanced line driver.

The configurations are extensive despite the simplicity, since various other projects can be used as the front end. For example, using 4 of the P94 PCBs would allow you to have two stereo line inputs (direct via pots), a stereo phono input (using P06) and a stereo mic input (with a P66 board), each with its own level and tone controls.

A stereo master volume control then lets you set the overall level, and the individual channel levels are set using their respective level controls.

Description

The circuit is very simple, and the PCB (available now) is extremely small (approx 50 x 75 mm). The idea is that one PCB would be wired with all components (Figure 1 and Figure 2), while the others only use the section shown in Figure 1. You can select the inputs you need, and add the appropriate input circuits, such as phono preamps, mic preamps, etc. Indeed, the range of uses is determined more by imagination than any "limitations" in the circuitry itself.

The first stage (U1) is a buffer, but provides a gain of 2 (6dB) as shown. The gain is easily changed by changing the value of R104 (and R204 in the "B" Channel) - a higher value gives less gain, and vice versa. I don't recommend that the gain be increased beyond about 4 times (12dB), or DC offset will become a problem. A value of 2k7 (2.7k) for R104/204 will give a stage gain of 3.7 (11.4dB) which should be more than enough. A microphone preamp is a must if very low level signals are intended.

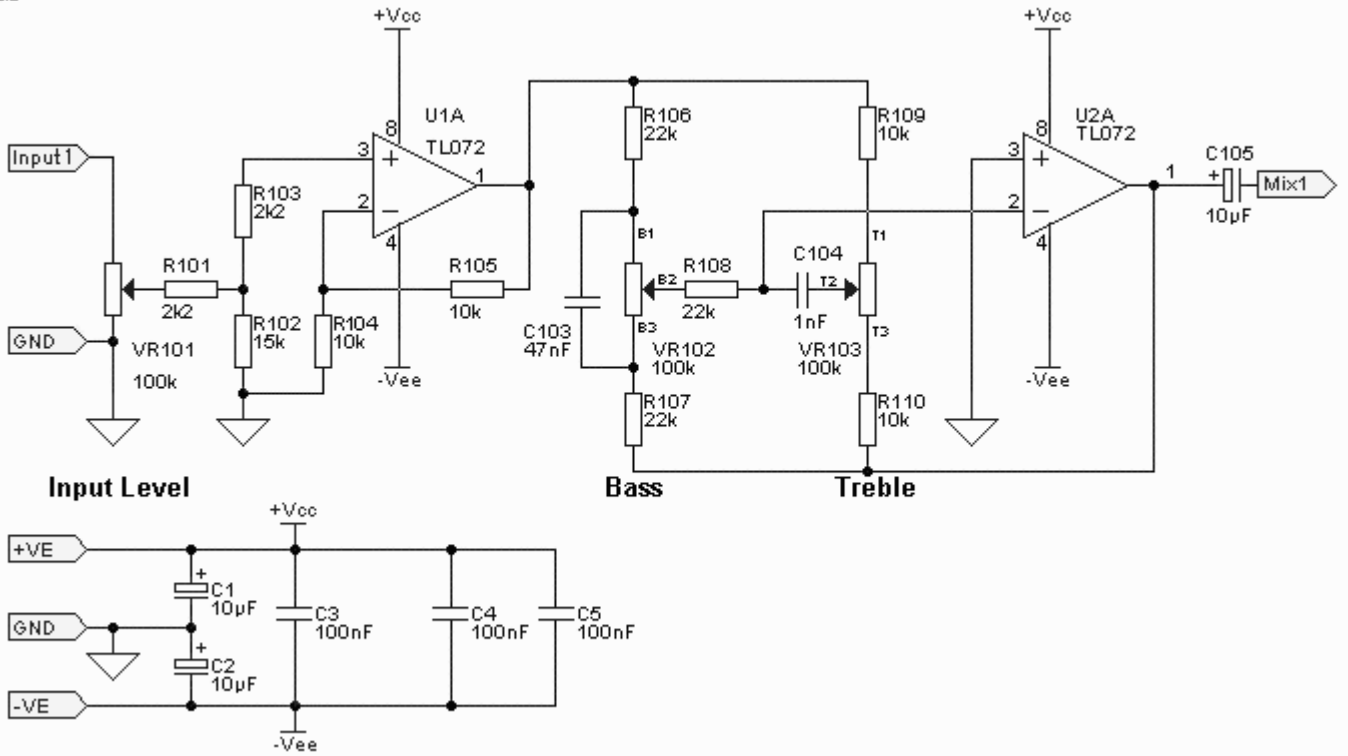

Figure 1 - Input and Tone Controls

The second stage is a standard Baxandall feedback tone control, and will give an almost dead flat frequency response with the controls in the centre position. For stereo, use dual pots all round, but for mono, single pots will be needed. The tone control response curves are shown in Figure 3. The small markings on the pots (e.g. B1, B2 and B3) are references to the PCB connections

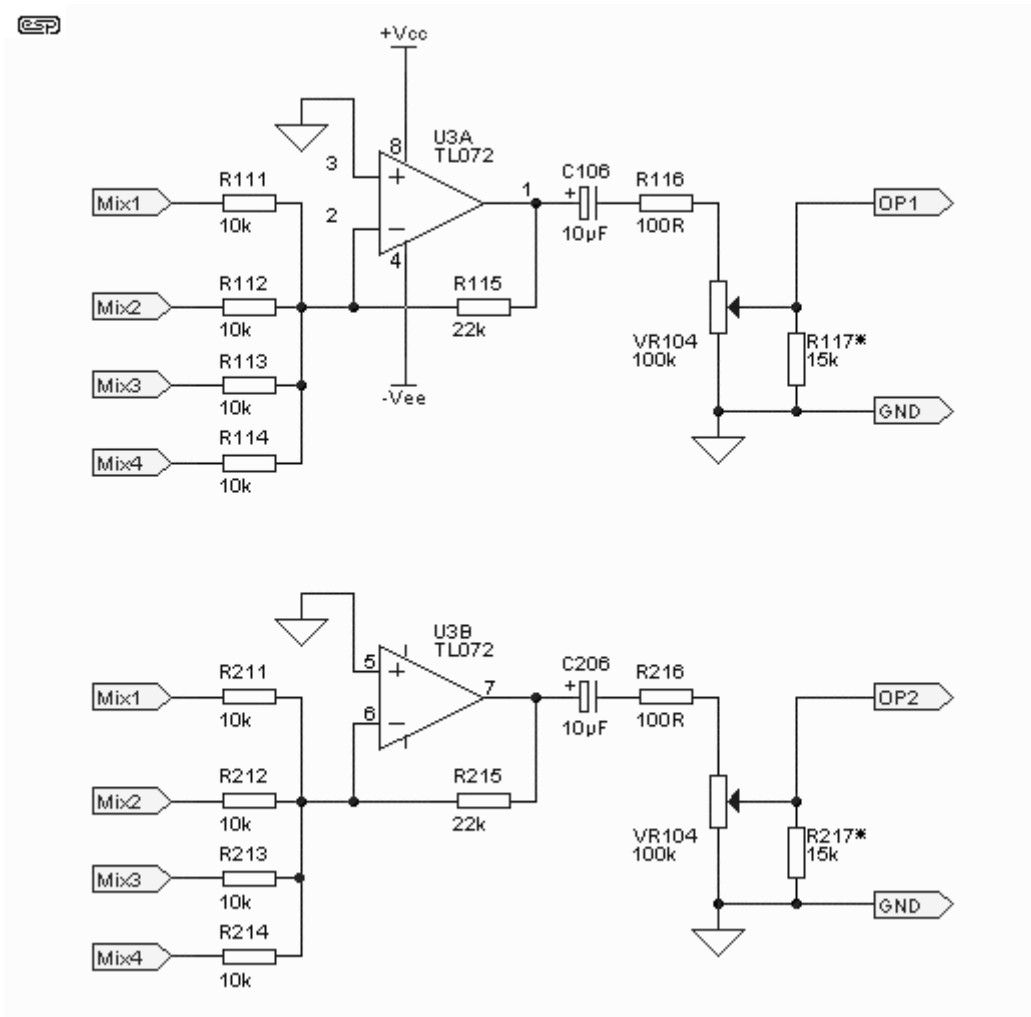

Figure 2 - Mixer Amplifier

The mixer is the common "virtual earth" mixing amplifier, and there is nothing special about it. Note that it is inverting, which complements the tone controls (also inverting) so the absolute signal polarity is maintained. As shown, the mixer also has a gain of a little over two times, and again this can easily be changed. Making R115/215 10k sets the gain at -1 (i.e. unity, but inverted). Note that R117/217 are not mounted on the board, but mount directly on the output level control.

Worst case output impedance is a little under 10k, so this unit is not suitable for driving long signal leads. VR104/204 can be reduced in value if you want, but if good quality low capacitance leads are used, I doubt that you'll have any problems.

All potentiometers are linear taper. The resistor values are selected to give a log "law" as described in Project 01 (where needed).

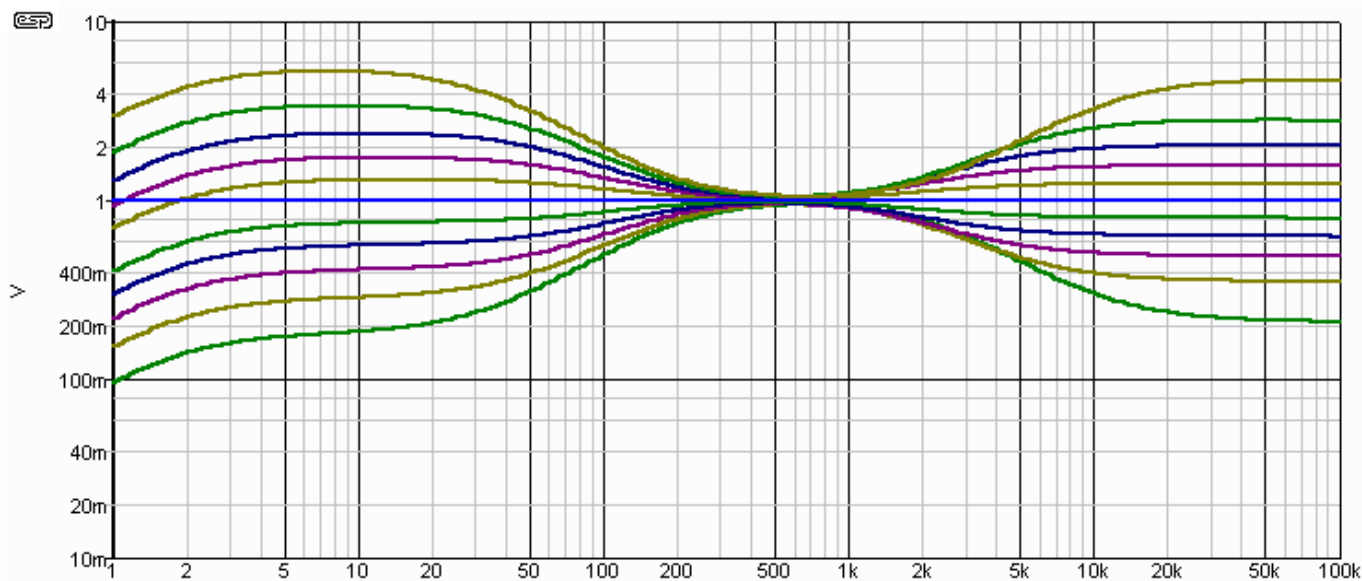

Figure 3 - Tone Control Response

Figure 3 shows the frequency response with the controls at 10% intervals. The centre frequency is deliberately set lower than the "industry standard" 1kHz, which (IMO) is an extraordinarily non-sensible place to set the bass turnover frequency. You will notice that there is a small "flat" section, between 500Hz and a little under 1kHz.

Bass response may be changed by using a different value for C103/203 (higher value, lower frequency), and likewise C104/204 control the high frequency point (lower value, higher frequency). I expect that most users will find the values to their liking as shown, but it can be changed quite easily.

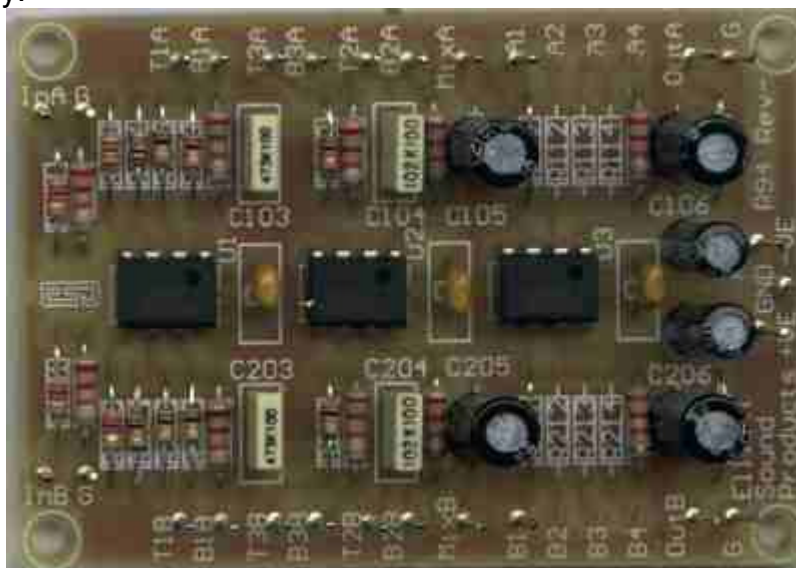

Photo of Completed PCB (No Wiring Shown)

The photo of the PCB shows the standard preamp connection, and you can see that the remaining mixing resistors have been omitted. This was done for testing (to make sure there were no errors on the PCB), and is a perfectly valid option for normal use.

Construction

If the ESP board is used, construction is very easy. It is small, but laid out very logically so it is easy to construct. No pots are mounted on the PCB - not because I like running wires (and I don't expect you do either) but because this gives you far greater flexibility for your version of the project. If I designed the board with the pots, then you would have to use the same type as I designed for, and the same spacings and layout. This is very restricting - especially if you can't get (or don't want to use) the same type of pot.

The circuit can also be laid out on Veroboard, but will be somewhat larger (and harder to work on) than the PCB.

The power supply may be from $\pm 9V$ (for portable use), or $\pm 15V$ for use with the P05 power supply. Any dual supply may be used, so if you have one already, it may be used as long as the voltage is between $\pm 9V$ and $\pm 15V$. Higher or lower voltages are not recommended.

I have shown the circuit with TL072 opamps, but you may use anything you like (must be an industry dual opamp though).

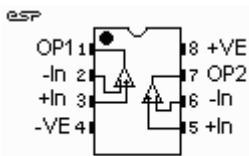

The standard pinout for a dual opamp is shown on the left. If the opamps are installed backwards, they will almost certainly fail, so be careful.

The suggested TL072 opamps will be quite satisfactory for most work, but if you prefer to use ultra low noise or wide bandwidth devices, that choice is yours.

Remember that the supply earth (ground) must be connected! When powering up for the first time, use 100 ohm to 560 ohm "safety" resistors in series with each supply to limit the current if you have made a mistake in the wiring.