

Simple Line Mixer and Patchbay

By Jon Tirone

(Also known as John Fisher)

Because we needed a mixer for some shows that our band is doing, I felt the need to make a simple line mixer to run the sound modules through in the studio to free the Mackie mixer for our shows. Up until now it has been a real hassle to yank out the Mackie from the studio everytime we had to do a show.

Because of the fact that I am more and more doing all of my recording , mixing and sound processing in the computer instead of using outboard gear, a simple line mixer is all I really need. There is also an advantage in it's simplicity in that there are very few gain stages because there is no EQ, panning or any effects busses. This makes the setup much quieter than when I was using the Mackie.

In the computer I use a "Gina" card and a "Yamaha, DSP Factory" card. This has excellent quality and it has the same features as a "Yamaha O2R" mixer. Even if you have a half decent computer you can still use the many plugins available and still use very little outboard gear.

I build the mixer as simple as possible because of the time factor, and also to avoid unnecessary noise that a more complex design could create.

It consists of 5 stereo inputs to plug in 5 stereo sound modules and a stereo out with volume controls.



Here is a photo of the device. (Note: I didn't have all of the knobs at the time I took this picture but here it is anyway.)

Because I don't own a sheet metal shop and I have very little tools, I decided to make the box out of some aluminum U channel stock. I think they use this for aluminum door frames or something. It is about 3-1/4" wide and the lip is about 3/4". The front pannel is the same width as a Rack mount device and it takes up 2 Rack spaces. One nice thing about using this is that the surface is actually glazed with

some sort of painted finish. This is a help because it's rather difficult to paint over raw aluminum.

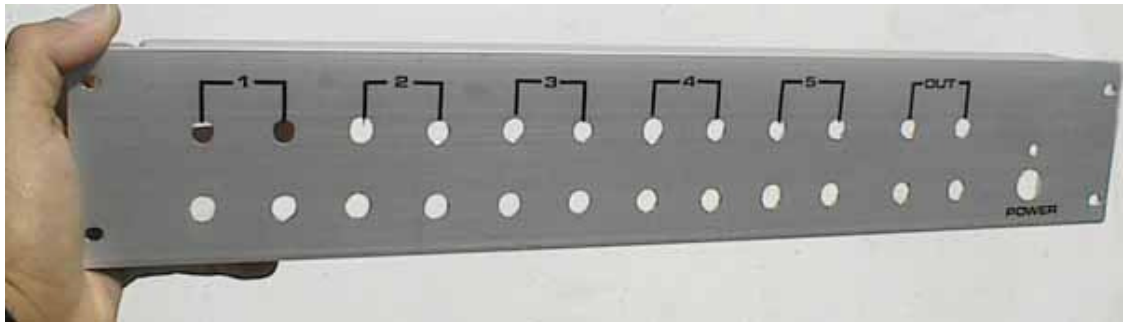

Although it's relatively easy to get more elaborate, I made a simple faceplate using Letraset and then spraying over the surface with clearcoat to protect the Letraset. This gives it a professional look that is easy to do and is fairly durable. Although Letraset with lines is difficult to find, I used some pinstripe that you find in auto supply stores for the lines. This is what they use to put pinstripes on cars.



By making different cuts with a hacksaw I then simply bent over the tabs with a pair of pliers. I used the same principal for the back to complete the box. I used a very small transformer for the power supply (about 100mA) so it would fit ok in the enclosure. I mounted the transformer and power supply on the back piece.

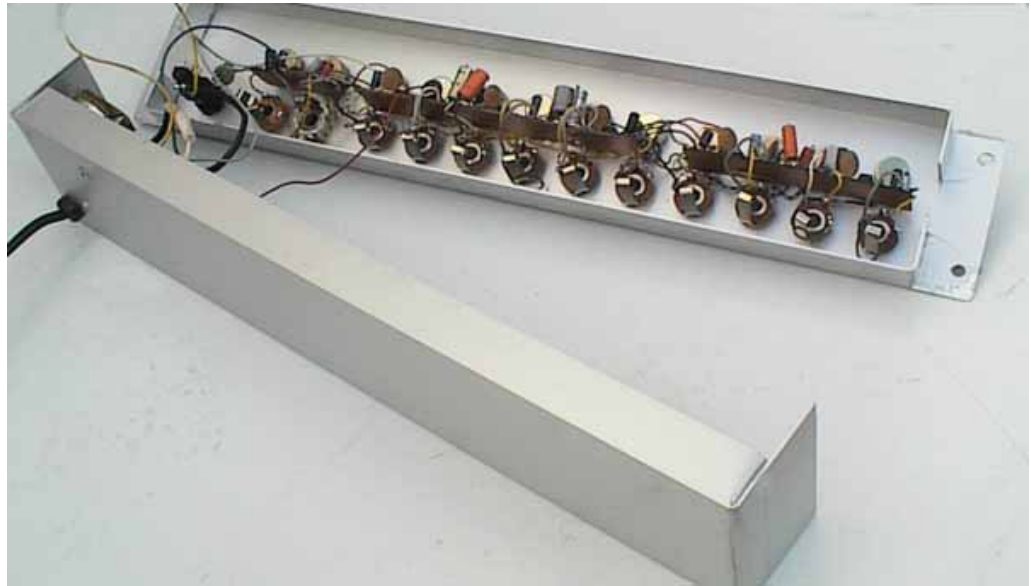

This is not a "do everything" mixer but it is ideal for what I need it for and it handles a line input just fine. I made it so all the jacks are in the front for easy access like a patch bay.

The components I used were from things I just had at hand. For example the 10K pots are linear pots but I would of preferred to use log pots if I had them. I'm sure that the design could be a little different but I just kind of stumbled through it from scratch and it works really good. With the volume controls on full the output is about 3-6 db louder then the input which gives a little leeway for whatever the need.

I have not done any elaborate tests but the thing sounds good to me and I could not hear any noise.

LINE MIXER

by
Jon Tirone

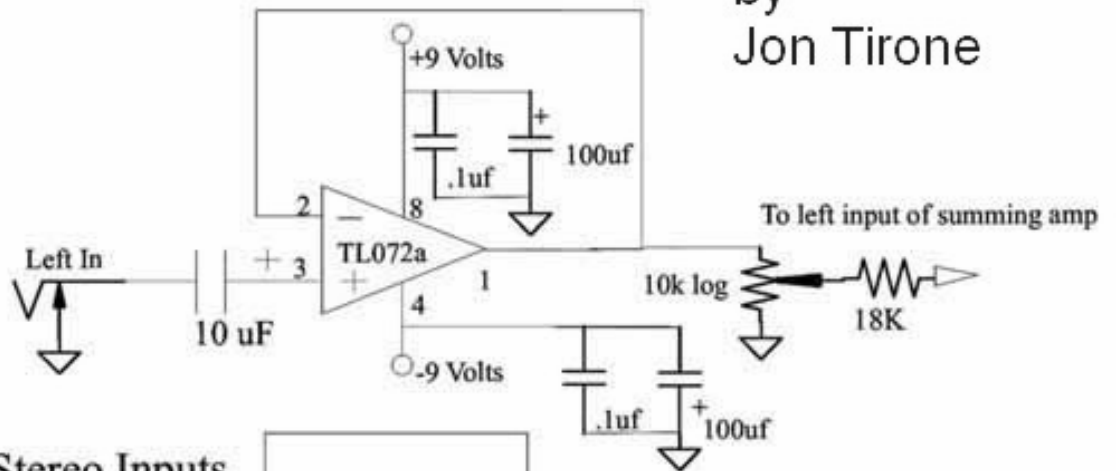

One of 5 Stereo Inputs

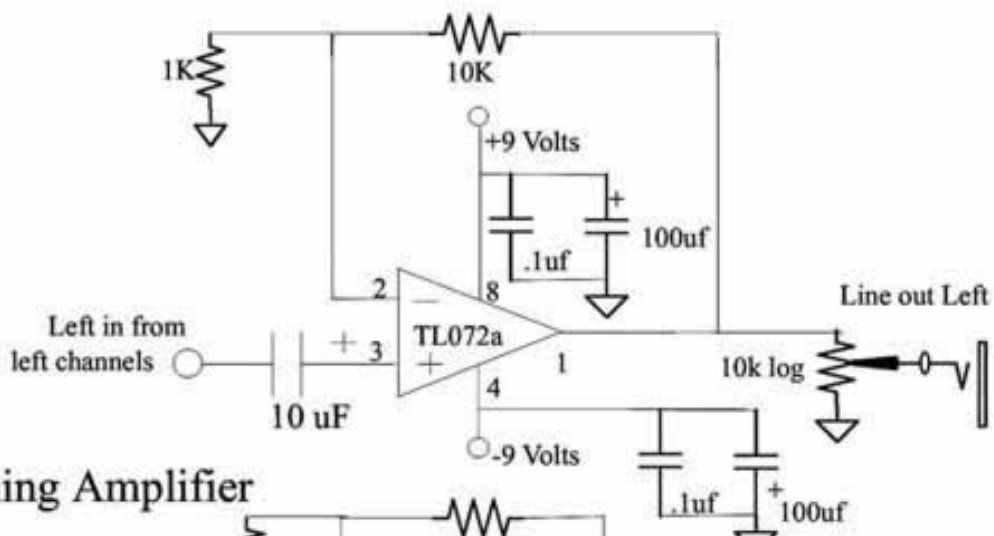
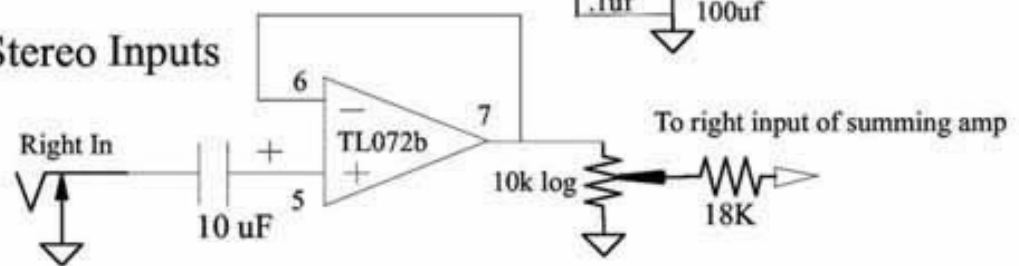

Summing Amplifier

