

Portable Microphone Preamplifier

High headroom input circuitry 9V Battery powered

Circuit diagram:

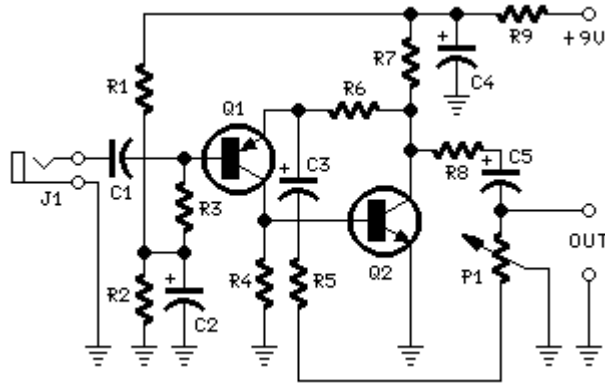

Parts:

P1 _____ 2K2 Linear Potentiometer

R1,R2,R3 _____ 100K 1/4W Resistors

R4 _____ 8K2 1/4W Resistor

R5 _____ 68R 1/4W Resistor

R6 _____ 6K8 1/4W Resistor

R7,R8 _____ 1K 1/4W Resistors

R9 _____ 150R 1/4W Resistor

C1 _____ 1 μ F 63V Polyester Capacitor

C2,C3,C4 _____ 100 μ F 25V Electrolytic Capacitors

C5 _____ 22 μ F 25V Electrolytic Capacitor

Q1 _____ BC560C 45V 100mA Low noise High gain PNP Transistor

Q2 _____ BC550C 45V 100mA Low noise High gain NPN Transistor

J1 _____ Jack socket (Mono 3 or 6 mm.)

Device purpose:

This circuit is mainly intended to provide common home stereo amplifiers with a microphone input. The battery supply is a good compromise: in this manner the input circuit is free from mains low frequency hum pick-up and connection to the amplifier is more simple, due to the absence of mains cable and power supply.

Using a stereo microphone the circuit must be doubled. In this case, two separate level controls are better than a dual-ganged stereo potentiometer.

Low current drawing (about 2mA) ensures a long battery life.

Circuit operation:

The circuit is based on a low noise, high gain two stage PNP and NPN transistor amplifier, using DC negative feedback through R6 to stabilize the working conditions quite precisely. Output level is attenuated by P1 but, at the same time, the stage gain is lowered due to the increased value of R5. This unusual connection of P1, helps in obtaining a high headroom input, allowing to cope with a wide range of input sources (0.2 to 200mV RMS for 1V RMS output).

Notes:

- Harmonic distortion is about 0.1% @ 1V RMS output (all frequencies).
- Maximum input voltage (level control cursor set at maximum) = 25mV RMS
- Maximum input voltage (level control cursor set at center position) = 200mV RMS
- Enclosing the circuit in a metal case is highly recommended.
- Simply connect the output of this device to the Aux input of your amplifier through screened cable and suitable connectors.