

Phono Preamps For All

Diagrams by Richard Crowley, Text by Rod Elliott

Introduction

This is a collection of phono (black vinyl for the youngsters) preamps and equalisation circuits, one of which is sure to meet your requirements. These are not my circuits, but were contributed by a reader (see above), so I am not really in a position to make any specific recommendations. They are provided as a service to the experimenters out there, and may be found useful for other applications as well.

Moving Coil Preamps

The first set of offerings are moving coil preamps, specifically intended for the very low output voltage and impedance of the majority of moving coil pickups. These were much favoured in their day for superior quality over the entire audio range, and for any serious listening I still use my moving coil pickup.

MC Preamp #1

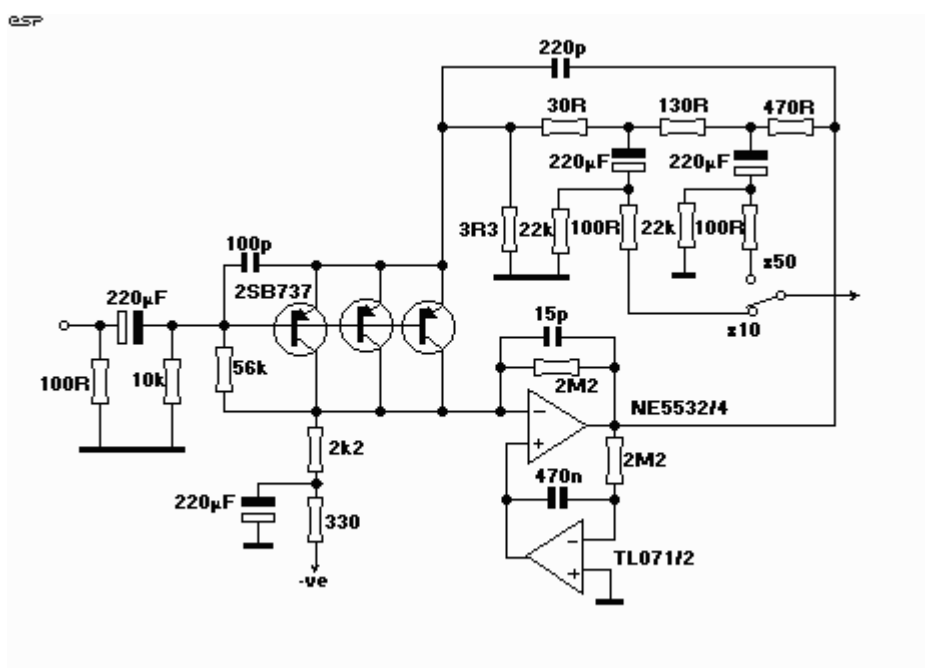

Figure 1 - Moving Coil Preamplifier (After Douglas Self)

This design uses multiple transistors as the initial amplifying stage. The transistors chosen have very low noise, and this is reduced even further by the parallel technique.

As can be seen from the diagram, the circuit gain can be changed to suit high and low output cartridges with a single switch. The gains as shown are x10 and x50 (20 dB and 34 dB respectively), but could be modified if desired. I will leave this up to the reader to experiment with.

As I look at the circuit, I'm not sure why the gain resistors were set up as they are. With the values shown, the circuit actually has a gain of 192 (set the feedback resistors in series and the 3.3 Ohm emitter resistor), and this is then attenuated to provide the gains of 50 and 10 as shown. I'm sure there was an excellent reason for this arrangement, but I cannot see it.

The second opamp (TLO71/72) acts as a bias servo device, and ensures that the inverting input of the NE5532 is at the same voltage as its non-inverting input. With this arrangement, output offset voltage can be expected to be very low - typically no more than a couple of millivolts.

MC Preamp #2

This next design is based on the work of John Linsley-Hood, and again can be expected to give good results. As can be seen, there are no opamps used, and the circuit is completely symmetrical. This offers a reduction in noise over a single circuit, since the two complete mirror image halves are in parallel. Distortion is probably reduced as well, but at the signal levels produced by a moving coil pickup, this is not likely to be significant.

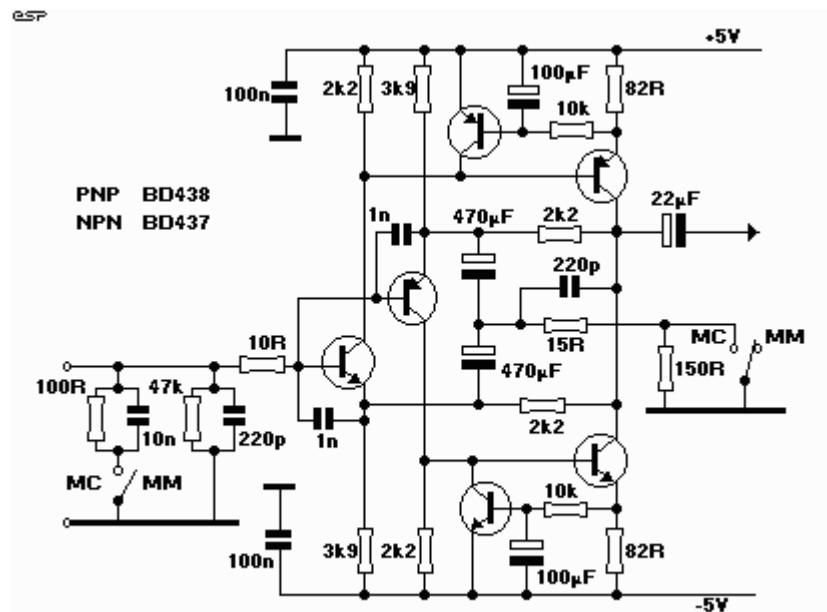

Moving Coil Preamp (After John Linsley-Hood)

The circuit is (more or less) conventional, using a common emitter stage modulating a constant-current source. As the circuit is mirrored, these are reproduced for both positive and negative supplies. The net output voltage will again have a low DC offset, but probably somewhat higher than the previous design due to the lack of a bias "servo" to maintain an exact 0V DC output.

Gain is set by the 2.2k resistors from the collectors of the output devices (in parallel, so 1.1k) and the 15 Ohm resistor (MC or Moving Coil position) optionally in series with the 150 Ohm (MM or Moving Magnet position).

These give a theoretical gain of 74 (37 dB) in the MC position, or 7.6 (17.6 dB) for the MM setting. In practice, one can expect the gain to be very slightly less than these figures, especially for the MC setting.

I cannot comment on the relative noise performance of these two preamps, but as they are both based on designs by well respected audio designers, I would expect that noise would not be an issue with either circuit.

Phono Equalisers

With two different circuits and several additional EQ networks to choose from (plus my own version, published as [Project 06](#)), there has to be one for you!

I do not know the origin of these circuits (other than from Richard), so cannot be too specific about them. They are both reasonably conventional, as can be seen.

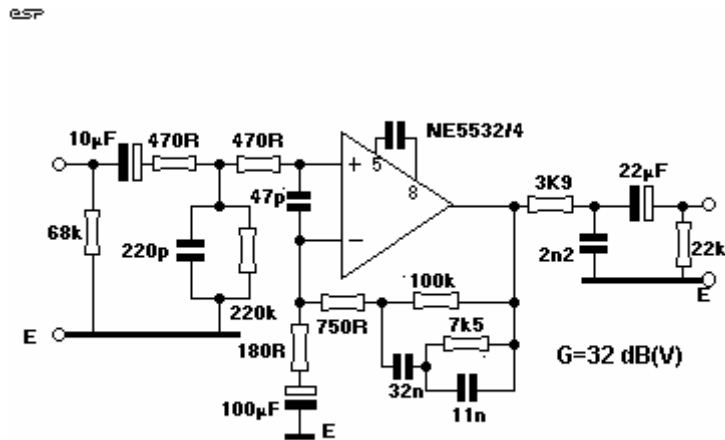

Figure 3 - Phono Preamp #1

This is a simple, one opamp phono preamp, but has a few added features. These are mainly for radio frequency (RF) suppression, and with the input circuit shown can be expected to be highly resistant to even high levels of RF interference.

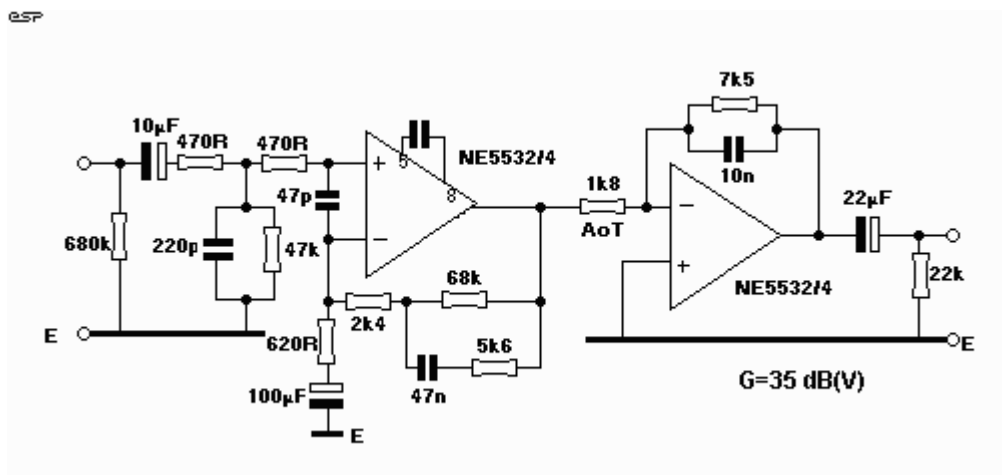

Figure 4 - Phono Preamp #2

This preamp splits the equalisation into two stages - the first stage provides the low frequency boost required by the RIAA specification, and the second reduces the high frequency component (again, to the RIAA spec.).

The advantage of this approach is that the two filter sections have less interaction, and much of the circuit noise produced by the first (and second) stage is attenuated by the top-cut circuit.

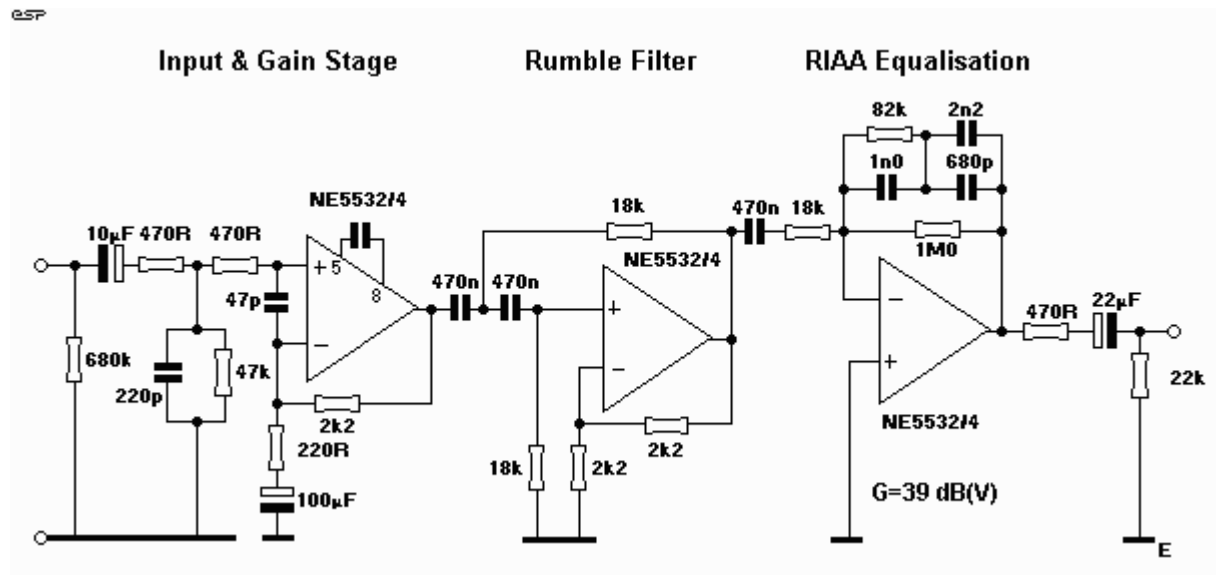

Figure 5 - Phono Preamp #3

As can be seen, this preamp is considerably more complicated than the first two, but includes a 3rd order rumble filter with a cutoff frequency of about 18 Hz.

The first stage is a simple amplifier, again with complete RF interference protection. This is followed by the rumble (infra-sonic) filter, and finally the equalisation stage. Note that in this circuit arrangement, the opamp is operating as an inverting amplifier, which has no bearing on the final result, but is (very) slightly noisier than the non-inverting configuration. This is unlikely to be audible in practice, since the gain contributed by the final stage is much lower than normal.

Total gain is 39 dB, of which 17.5 dB is contributed by the input stage, 6 dB by the filter, leaving only 15.5 dB gain in the final stage. All preceding high frequency opamp noise is attenuated by the RIAA equalisation, leading to a design which should have an excellent overall noise figure.

Equalisation Networks

These EQ networks can be used around any opamp, and will provide RIAA equalisation to an accuracy as shown next to each diagram. Some care must be used to ensure that the feedback resistor (to ground) is selected to give the required gain.

This is specified at 1 kHz for all phono preamps, because of the frequency characteristics of the filter network.

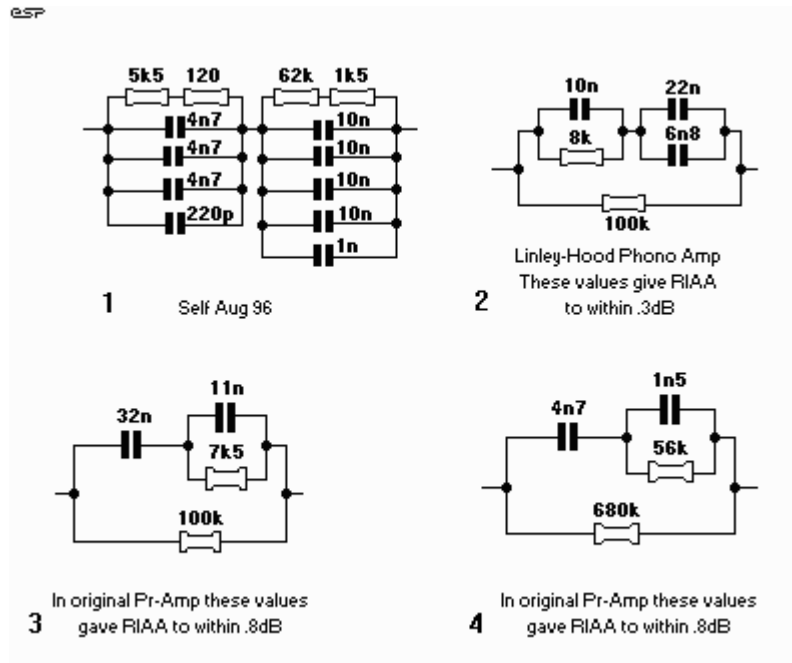

Figure 6 - Various RIAA Phono EQ Networks

Note - I have been advised by a reader that the 1nF capacitor in Figure 6-1 should be 10nF. I do not have the original circuit diagram for this preamp, so cannot be sure, but it is worth bearing in mind if you use the EQ network. A calculation reveals that there should be 50nF in parallel with 63,500 ohms to obtain 50Hz, so I expect that the 1nF cap is indeed incorrect.

The 1 kHz impedance of each network is quite different, so the required feedback resistor has been calculated for a nominal gain of 35 dB (x 56) . These work out to (approximately)

Circuit Nbr.	Network Z	Feedback Res.	Actual Gain
1	7.75 k Ohms	138 Ohms	56.6
2	10 k Ohms	180 Ohms	57.0
3	9.43 k Ohms	168 Ohms	56.6
4	67 k Ohms	1.2 k Ohms	56.8

With this in mind, the 1 kHz gain resistor can be calculated. For example, using (1) above, for a gain of 35 dB (a gain of 56 for ease of calculation), this will need a resistor to ground from the -ve input of the opamp of 138 Ohms.

RIAA Equalisation Response

For the sake of reference, the table below shows the response curves for both RIAA equalisation, and the IEC modified version. The latter was not very popular, because it represented a loss of bass (-3 dB ref RIAA at 20 Hz). For anyone wanting to know a little more about how and why the equalisation was done in this way, read on.....

Hz	RIAA	IEC	Hz	RIAA	IEC	Hz	RIAA	IEC
20	19.36	16.35	240	7.04	7.01	2400	-3.39	-3.39
22	19.24	16.62	270	6.25	6.23	2700	-4.04	-4.04
25	19.04	16.89	300	5.57	5.55	3000	-4.65	-4.65
28	18.83	17.04	340	4.80	4.79	3400	-5.43	-5.43
31	18.61	17.09	380	4.16	4.15	3800	-6.17	-6.17
35	18.29	17.06	430	3.49	3.48	4300	-7.02	-7.02
39	17.96	16.95	480	2.93	2.92	4800	-7.82	-7.82
44	17.54	16.73	540	2.38	2.38	5400	-8.70	-8.70
49	17.12	16.45	610	1.86	1.86	6100	-9.64	-9.64
55	16.61	16.07	680	1.43	1.43	6800	-10.50	-10.50
62	16.02	15.59	760	1.02	1.02	7600	-11.39	-11.39
70	15.37	15.03	850	0.63	0.63	8500	-12.30	-12.30
79	14.67	14.40	950	0.26	0.26	9500	-13.22	-13.22
89	13.93	13.72	1100	-0.23	-0.23	11000	-14.44	-14.44
100	13.18	13.01	1200	-0.52	-0.52	12000	-15.17	-15.17
110	12.54	12.39	1300	-0.79	-0.79	13000	-15.85	-15.85
120	11.94	11.82	1500	-1.31	-1.31	15000	-17.07	-17.07
130	11.38	11.27	1700	-1.80	-1.80	17000	-18.14	-18.14
150	10.36	10.28	1900	-2.27	-2.27	19000	-19.09	-19.09
170	9.46	9.40	2100	-2.73	-2.73	21000	-19.95	-19.95
190	8.67	8.62						
210	7.97	7.93						

RIAA Time Constants

The time constants ($2\pi f$) that provide RIAA equalisation are

- High Frequency = 75us (2122 Hz)
- Mid Frequency = 318us (500.5 Hz)
- Low Frequency = 3180us (50.05 Hz)

The basic principle behind the equalisation curve was quite simple, and was designed to reduce the groove modulation to a manageable level (both for the cutter and the reproducer), and provide some basic high frequency noise reduction.

With this in mind, frequencies below 500 Hz were "cut" using constant amplitude, which means that the signal from the cartridge will increase at 6 dB / Octave, since if the amplitude remains constant, the velocity must increase with the frequency. Because the output of a magnetic cartridge is dependent upon the velocity, bass boost must be applied to bring the levels back to normal.

It is this rather large amount of bass boost that accentuates the mechanical noise of a turntable, producing what is commonly known as "rumble". There is also the risk of low frequency feedback if the turntable is not capable of isolating the platter and tone-arm from the listening room environment. Timber floors and rigid suspension increase the risk of feedback, and many manufacturers went to extreme lengths to provide isolation and very low levels of low frequency noise.

Above 500Hz, the cutter mode changed to constant velocity, so the output of the cartridge will now be independent of frequency. Vinyl (or any other material for that matter) will collect dust, and will also have minor surface imperfections, so all signals above 2100 Hz are boosted (again at 6 dB / Octave), so the equalisation curve now applies treble "cut". This brings the signal level back where it should be, and reduces disc surface noise as well.