

Parametric And Sub-Woofer Equaliser

Rod Elliott (ESP)

Introduction

Parametric equalisers are normally quite complex, and allow for variable Q (Quality factor), so the peak or dip can be made sharp or broad. This unit does not allow this, but the Q will vary as the amount of equalisation is varied. Perhaps surprisingly (or perhaps not), this works well in practice, and my unit has more than enough range for "normal" equalisation tasks.

I tend to feel that if a unit such as this is not capable of removing the problem, then the actual cause of the problem should be investigated, rather than going for more complexity, and more radical variations in the relative phase of the signal.

This unit is not intended for hi-fi (although it can still be used with care), but as a diagnostic tool it is extremely useful. If sonic problems are encountered, some experimentation with one (or more) parametric equalisers can be helpful in identifying the nature and magnitude of the problem.

The Circuit

The schematic is shown in Figure 1, and is quite simple. In essence, it uses the same principle as a graphic equaliser, but the "simulated inductors" are made variable, so the frequency can be swept back and forth. The four 10K pots provide cut (when on the left or anti-clockwise side of centre) or boost, and in the centre position have no effect at all. Maximum boost and cut is about 12 to 14dB (typical).

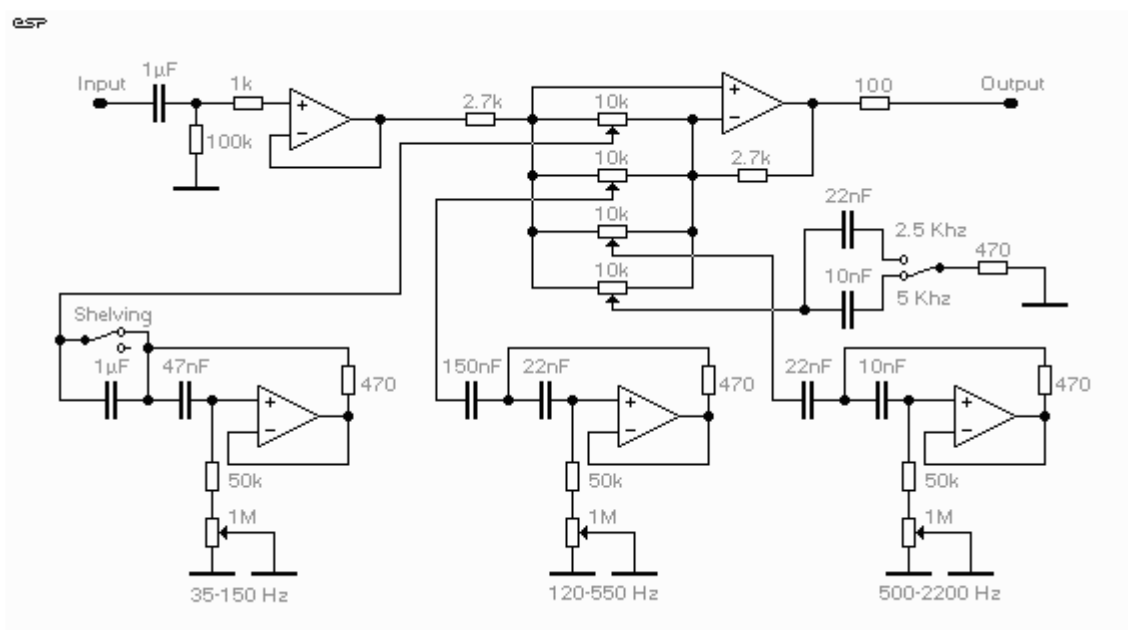
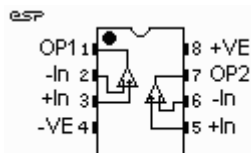

Figure 1 - The Circuit Of The Parametric Equaliser

The low frequency section can be swept from 35Hz to 150Hz in peaking mode (this is the normal form of operation for a parametric equaliser), but also offers the option of shelving. Shelving is similar to the operation of "normal" tone controls, but this is also sweepable, so the frequency can be changed to suit your requirements. Frequency increases as the 1M pots are reduced in value.

There are two mid-range sections, one operating between 120Hz and 550Hz, and the other from 500Hz to 2200Hz. The high frequency EQ is shelving only, and can be switched from 2.5kHz to 5kHz with the values shown. By changing capacitor values, these can be easily modified, or you can use a multi-position switch to add as many frequency points as you want.

The input and simulated inductor opamps can be TL072 types, but the output opamp needs to be fairly quiet. An NE5532 (for stereo) or NE5534 (for a mono version) would be a good choice. Remember that the NE5534 is not internally compensated, and will require an external capacitor to prevent oscillation.



IC pinouts for dual opamps are shown in the diagram. Remember that all opamps need bypass capacitors on the supply pins, and I suggest that a 10uF electrolytic is used from both supply rails to earth for the whole board, and 100nF ceramic capacitors should be used as close as possible from each supply pin to earth. Keep all leads as short as possible.

If fast opamps are used, you will need to take great pains to ensure that the bypassing is effective, to prevent oscillation. The 100 ohm output resistor isolates the opamp output from the capacitance of the output cable.

Sub-Woofer Equaliser

This circuit can also make a very flexible sub-woofer equaliser, by leaving out the 500Hz to 2200Hz section and the treble control (thereby only using two of the 10K pots). The second section (120Hz to 550Hz) should be the same as the low frequency section, except without the Shelving switch.

With the ability to have two peaking filters, or one shelving and one peaking, the response of a subwoofer (and the listening space) can be tailored quite accurately. Additional bass boost can be added from (say) 50Hz and below, and any strong room resonance can be removed, or a prominent dip filled in.

The input filter provides a -3dB point of 1.6Hz, and if this is too low (few if any subs will go quite that low), it can be made more reasonable by reducing the 1uF cap to 100nF, raising the -3dB point to a more realistic 16Hz. Note that the -3dB point is only accurate when the boost/cut controls are set to the mid position, giving a flat response.

Simulated Inductors

Since this circuit relies on the simulated inductor, it is worth a few words on how these work. The opamp is used only as a buffer (emitter followers can also be used, but are not quite as good), and uses controlled positive feedback to make the circuit act as an inductor.

Looking at the first section (without the switch, though), there is a 47nF capacitor, 470 Ohm resistor, and a resistance that can be varied from 50k to 1.05M Ohms (the 50k fixed resistor plus 1M Ohm). The approximate formula for the inductance is:

$$L = R1 \times R2 \times C$$

So

$$L = 470 \times 50k \times 47nF = 1.1 \text{ Henrys} \quad \text{and with the pot at maximum}$$

$$L = 470 \times 1.05M \times 47nF = 23 \text{ Henrys}$$

With a series capacitance of 1uF, and since the resonant frequency is determined by

$$F_o = 1 / 2 \times \pi \times \sqrt{(L \times C)}$$

We obtain

$$F_o = 1 / 2 \times 3.141 \times \sqrt{(1.1 \times 1uF)} = 151\text{Hz} \quad \text{and}$$

$$F_o = 1 / 2 \times 3.141 \times \sqrt{(23 \times 1uF)} = 33.2\text{Hz}$$

These figures are more than accurate enough for our purposes. With this information, you can modify the frequency ranges to suit any application. Bear in mind that to be able to use these circuits at frequencies above about 3kHz or so, you will need to use fairly fast opamps. The venerable TL072 or its equivalent is probably good enough for most applications, but if additional frequency equalisation sections are to be added, a really quiet opamp should be used for the output stage (as stated above, I would suggest that this is a good idea anyway).