

# Dynamic Microphone Preamp

## Description:

A low noise pre-amplifier suitable for amplifying dynamic microphones with 200 to 600 ohm output impedance.

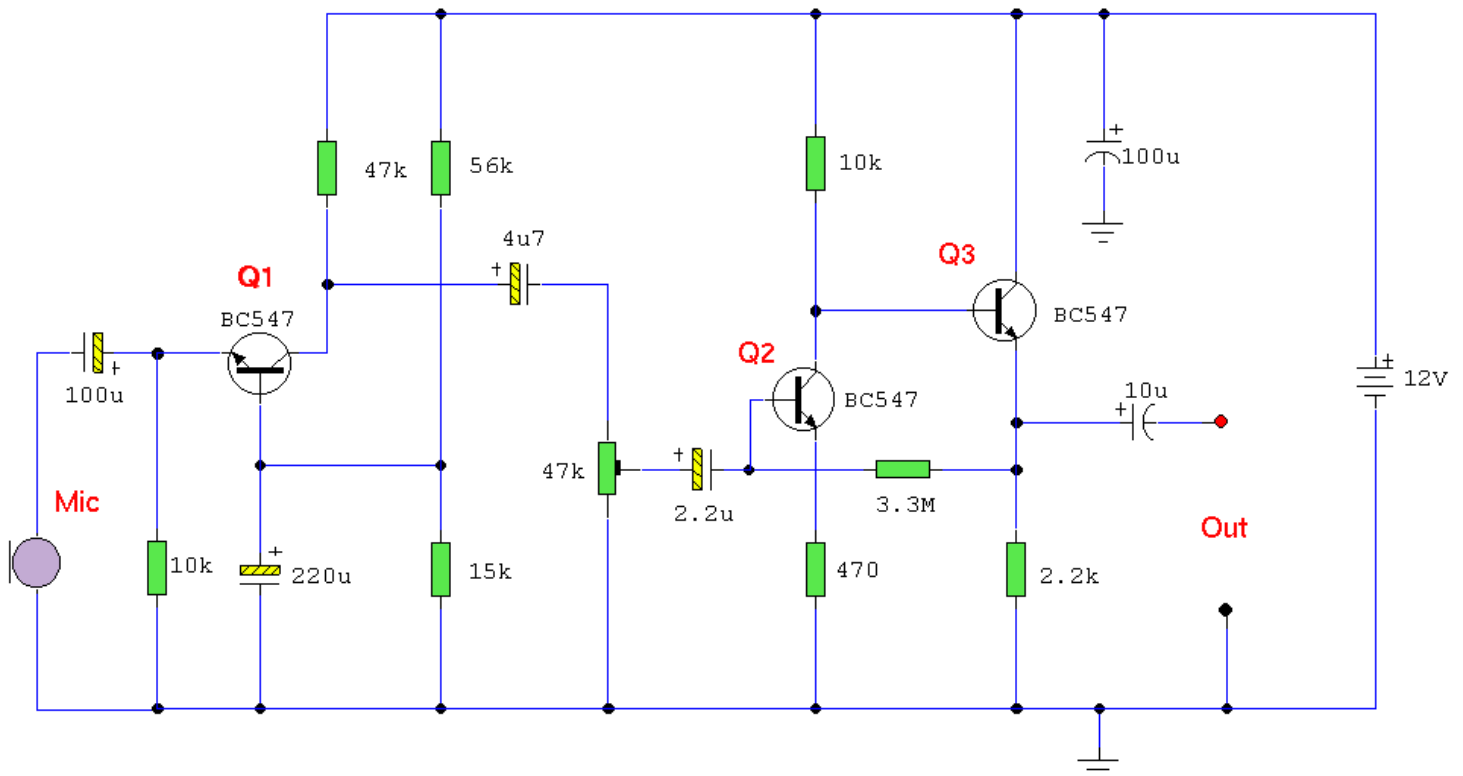

## Notes:

This is a 3 stage discrete amplifier with gain control. Alternative transistors such as BC109C, BC548, BC549, BC549C may be used with little change in performance. The first stage built around Q1 operates in common base configuration. This is unusable in audio stages, but in this case, it allows Q1 to operate at low noise levels and improves overall signal to noise ratio. Q2 and Q3 form a direct coupled amplifier, similar to my earlier [mic preamp](#).

## Input and Output Impedance:

As the signal from a dynamic microphone is low typically much less than 10mV, then there is little to be gained by setting the collector voltage of Q1 to half the supply voltage. In power amplifiers, biasing to half the supply voltage allows for maximum voltage swing, and highest overload margin, but where input levels are low, any value in the linear part of the operating characteristics will suffice. Here Q1 operates with a collector voltage

of 2.4V and a low collector current of around 200uA. This low collector current ensures low noise performance and also raises the input impedance of the stage to around 400 ohms. This is a good match for any dynamic microphone having an impedances between 200 and 600 ohms. The output impedance at Q3 is low, the graph of input and output impedance versus frequency is shown below:

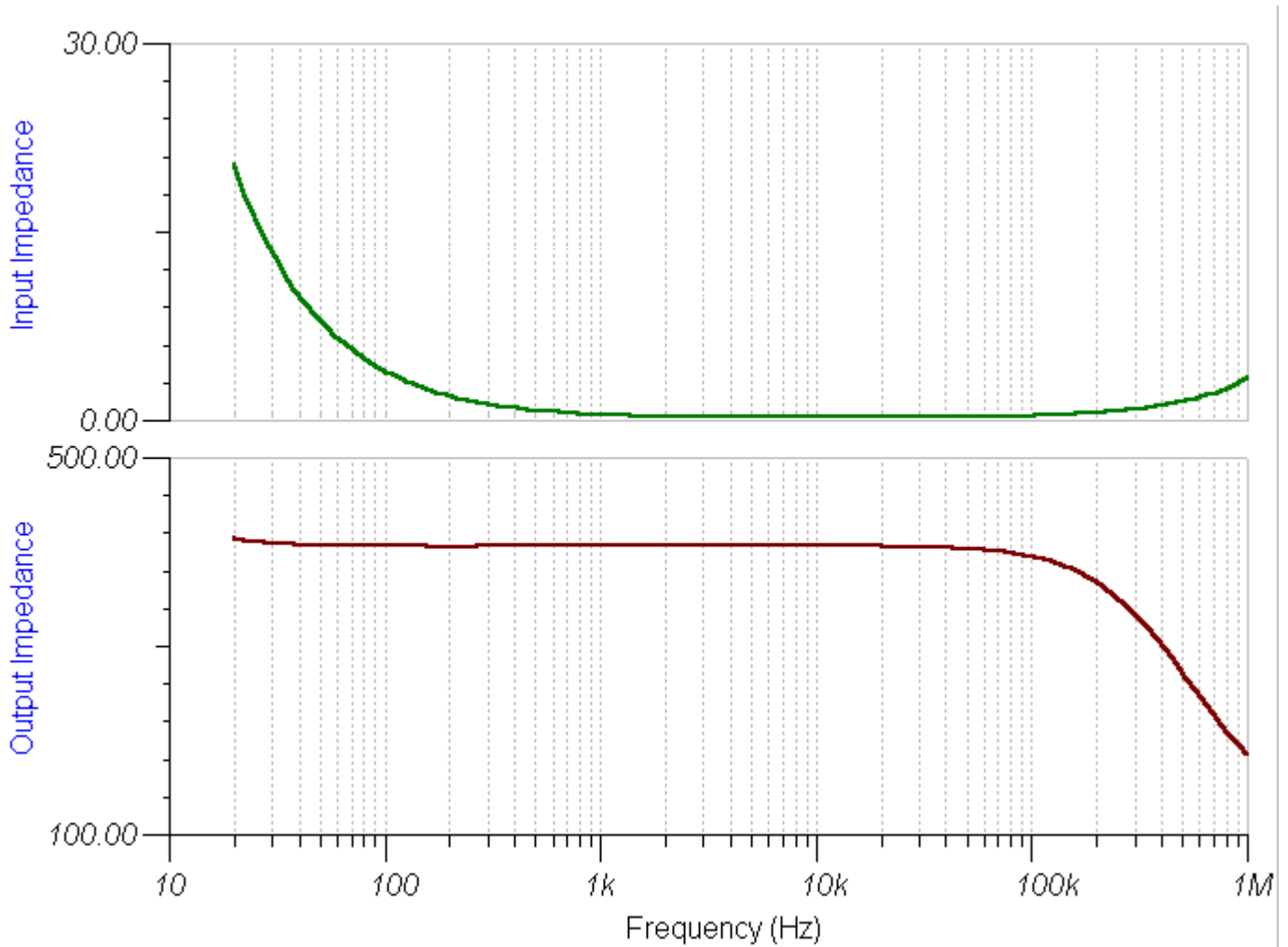

### Gain and Frequency Response:

The overall gain of this pre-amplifier is around +39dB or about 90 times. The first stage Q1 has a gain of roughly  $R_c / R_e$  or 4.7. This is however reduced by feeding into the input impedance of Q2 and Q3, and the shunt formed by the 47k preset. The amplifier formed with Q2 and Q3 has a gain of roughly  $R_c / R_e$  as Q3 is an emitter follower and has unity gain. The gain of Q2 and Q3 is roughly  $10 / 0.47 = 21$  and overall gain therefore  $4.7 \times 21 = 98$ . The gain of the circuit may be reduced to 0 by the 47k preset. The response is flat to 100kHz, low frequency rolloff at 30Hz, a simulated plot is shown below:

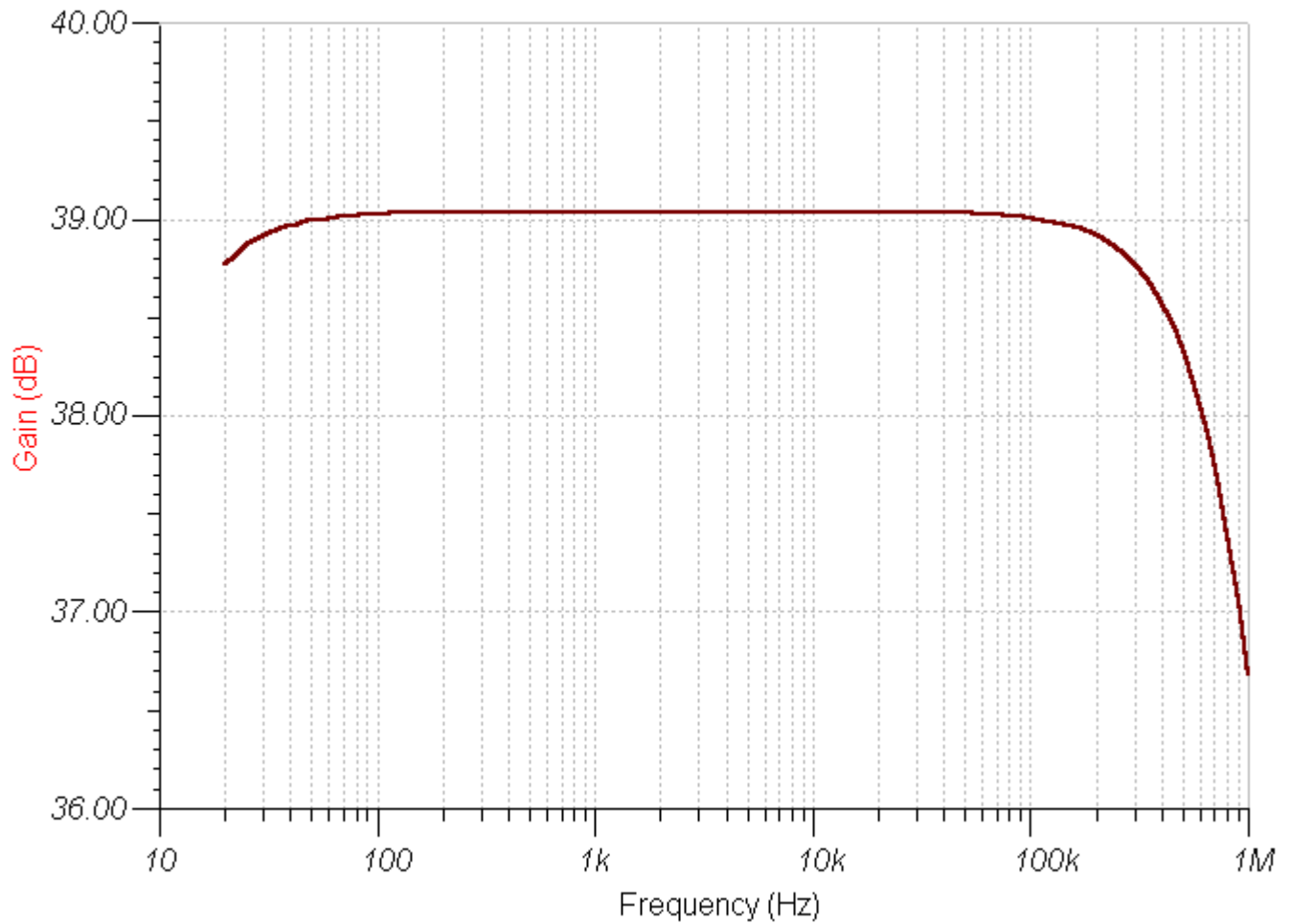

#### [Output Noise and Overall S/N Ratio:](#)

Any amplifier will add its own noise to the signal, degrading the overall performance. The noise of this preamp measured with a 10k load resistor is shown below.

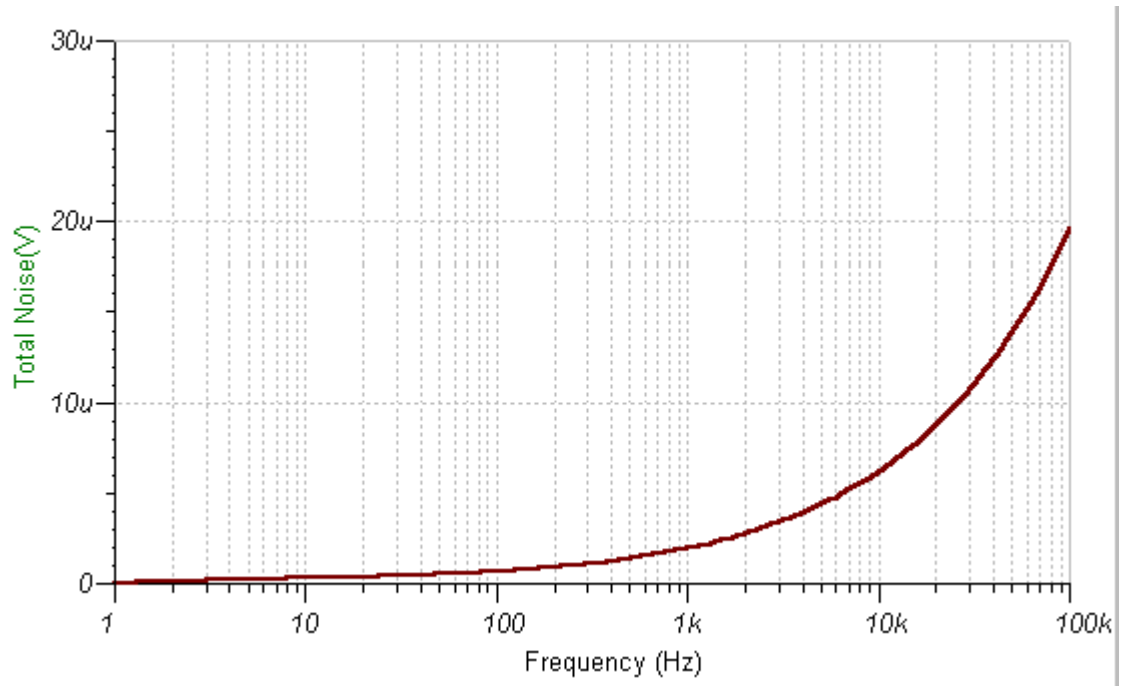

The Signal to Noise ratio is shown below. Note that the input was simulated as a 200 ohm source at 1 mV amplitude.

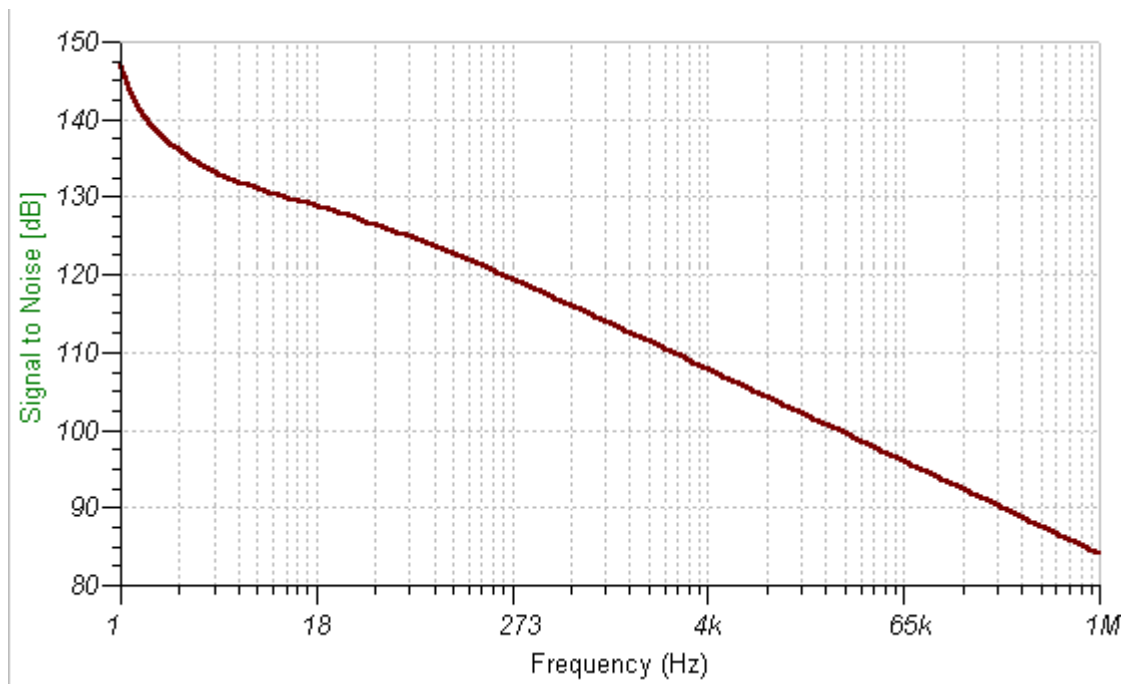

### Bias Conditions and Operating Point:

The first stage, Q1 was designed to operate with a collector current of 200  $\mu$ A. With 15k and 47k bias resistors and a 12 V supply voltage the base voltage will be  $12 \times (15 / (15+47)) = 2.9$  Volts. The emitter voltage will be the base voltage -0.7 V or 2.2 V. For a 200  $\mu$ A collector current the emitter resistor will be  $2.2 / 0.2 \text{ mA} = 11\text{k}$ . A 10k resistor was used. As  $I_c$  and  $I_e$  are approximately equal then the collector voltage is  $12 - (0.2 * 47) = 2.6$  V.

The last stage is a composite amplifier similar to my ECM preamp. Q2 operates in common emitter and provides the voltage gain while Q3 operates in emitter follower, buffering the output and has a low impedance output, suitable for driving long cables, if required. The last stage, Q3 was designed for maximum voltage swing, hence Q3 emitter voltage should be around 6 V. Variation in transistor parameters however, means that measured voltages will be different to calculated voltages. Q2 collector voltage is a base-emitter voltage drop higher or 6.7 V and collector current is set at  $(12 - 6.7) / 10\text{k} = 530$   $\mu$ A. This is also the emitter current for Q2 and hence emitter voltage will be  $(0.53 * 0.47) = 0.24$  V. The base voltage will be higher by 0.7 V. As the base of Q2 is connected to the emitter of Q3, then the biasing is stabilised to a certain degree against changes in temperature and current gain variation. However if a meter is available for testing transistor beta, then the transistor with the highest current gain should be used for Q2.