

'A' Weighting Filter For Audio Measurements
Rod Elliott - ESP (Original Design, based on an old Ampex circuit)
(Updated with improved filter - 29 Aug 2003)

Introduction

I have to say from the outset that I do not agree with the use of weighting filters, since they are not (despite the claims to the contrary) an accurate representation of human hearing.

In fact, the standard "A" weighting curve is accurate at only one SPL (Sound Pressure Level), assuming that the listener has British Standard Ears. I have no idea what SPL this filter is meant to be accurate at, and I doubt that anyone else does either (although at a rough guess I would suggest somewhere around 50dB and below).

When the police measure the noise from a car exhaust or a party, they happily use A-weighting (it's probably in the legislation - that has to be scary - politicians thinking that they know about SPL? Next thing they will tell us that they understand fiscal policy. But I digress

The purpose is supposedly to account for the fact that human hearing is less sensitive at low and high frequencies than in the upper midrange, and that this variation is dependent upon the sound intensity (SPL). The Fletcher-Munson curve (as it is commonly known, and reproduced below) shows the variation, and it is clear that any loss of sensitivity is highly dependent upon the actual SPL. The idea that a single filter can represent this at all levels is clearly wrong, but it is a standard nonetheless. (Interestingly, being wrong has never stopped a standard from being imposed, and this is probably truer in the audio industry than almost any other I can think of.)

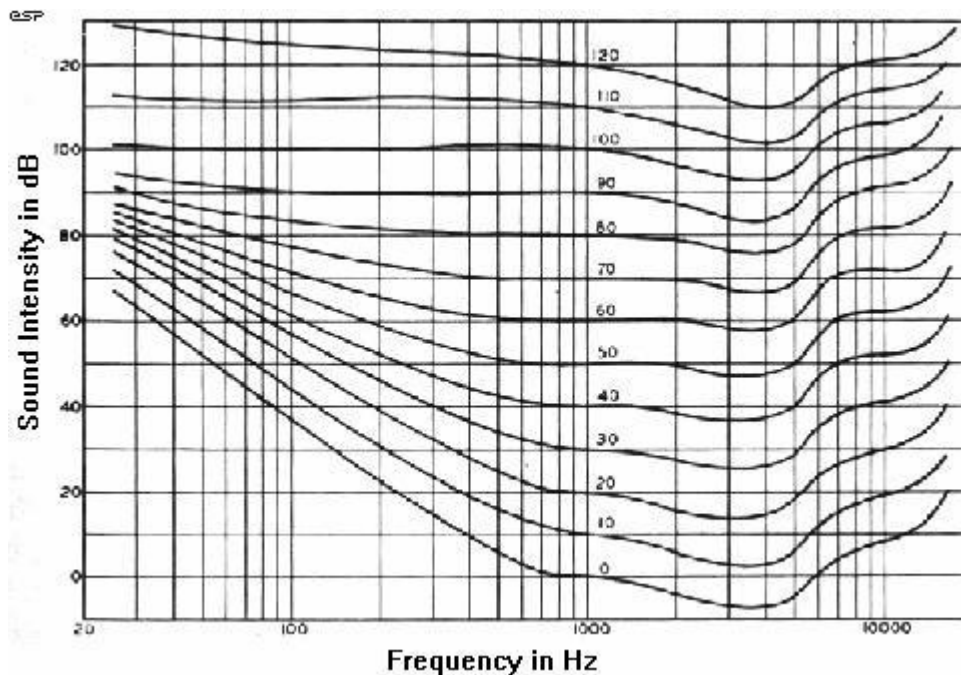

Figure 1 - Equal Loudness Curves (After Fletcher and Munson)

The premise behind all this is that as the SPL is reduced, our ability to detect low or high frequency noise is reduced, so measurements should reflect this phenomenon. While it is undeniable that the chart above represents reality in terms of human hearing [1], I remain unconvinced that A-weighting is a valid test methodology unless the absolute sound intensity is specified.

Ok, I agree that there just might be some validity hiding in there somewhere for noise measurements of amplifiers and the like, but just because the meter tells me that I should not be able to hear the harmonics of the 50/60Hz mains, does not mean that I cannot. There are some sounds that seem (at a casual glance) to defy all measurement standards, and remain audible (albeit at very low level) despite all the "evidence" that this should not be so. As with all such things, experience and practical application are more important than the absolute indication on a meter.

A piece of equipment that is essentially "noise-free" for all intents and purposes is in reality a waste of time, since the ambient noise level in most urban or suburban areas is likely to be far higher than the residual noise of most audio equipment. How useless is 100dB signal to noise ratio for a car hi-fi system, for example? Even the most expensive luxury cars generate far more noise than any tuner/cassette/CD system (and this is apart from all the other external noise generated by other vehicles on the road).

Description

Since it is unlikely that I shall be able to convince the entire industry that it is using flawed reasoning, I shall describe an A-weighting filter so that we can at least make some meaningful comparisons with other systems where this has been used. Note that A-weighting is generally applied only to noise measurements, so *might* have some validity in this respect (as long as the noise we are measuring is of very low amplitude - the neighbour's party is unlikely to fit this mould, but will be measured with A-weighting anyway - oh dear - so much for getting some sleep! (And yet again I digress))

The curve of the described filter is shown in Figure 2, and it can be seen that it is essentially a tailored bandpass filter, having a defined rolloff above and below the centre frequency. The reference point is at 1kHz, where the gain is 0dB. The filter response is supposed to be the inverse of one of the curves of the equal loudness graph shown in Figure 1 - it is a little hard to tell which one, but this is a standard, so we shall leave it at that.

As can be seen from Figure 3, the circuit is very simple, but even with this frequency response it is not particularly hard to calibrate accurately so that it really does account for our perception of noise level - especially if an accurate sinewave tone is used as the reference.

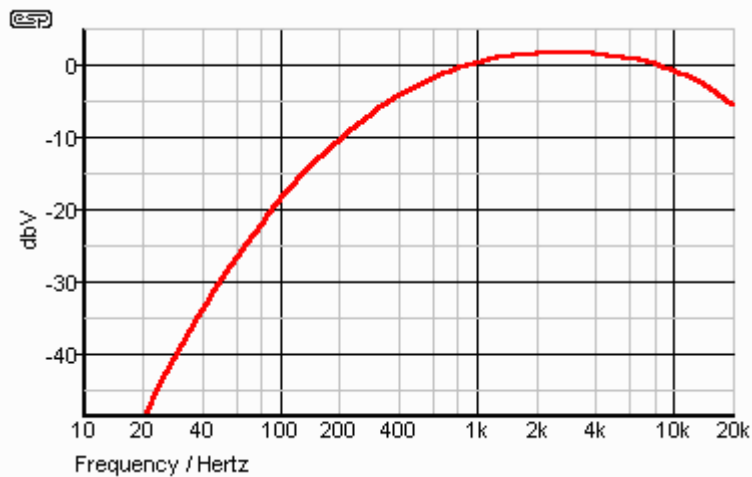

Figure 2 - Frequency Response of the A-Weighting Filter

The filter itself is passive, and the opamps are there only to buffer the input and output, and to adjust the gain so there is some correlation with reality (however slight). Note that the input impedance is quite low, and the output impedance is high, so the unit should be well shielded to prevent noise pickup from the outside world.

As always, I suggest the use of 1% metal film resistors, and the capacitors should be measured and selected, or close tolerance types used. If "ordinary" capacitors are used, their tolerance will adversely affect the accuracy, but for normal use (i.e. non-certified laboratory), it should be close enough even if 10% caps are used. After all, the noise level of any semiconductor amp is likely to be somewhat variable anyway, so extreme precision is not normally warranted.

The circuit can be operated from a pair of 9 Volt batteries, or a regulated supply of up to +/-15V. There is no need to use premium opamps unless extremely low noise levels are to be measured, and even then are not needed if there is a gain stage at the front end.

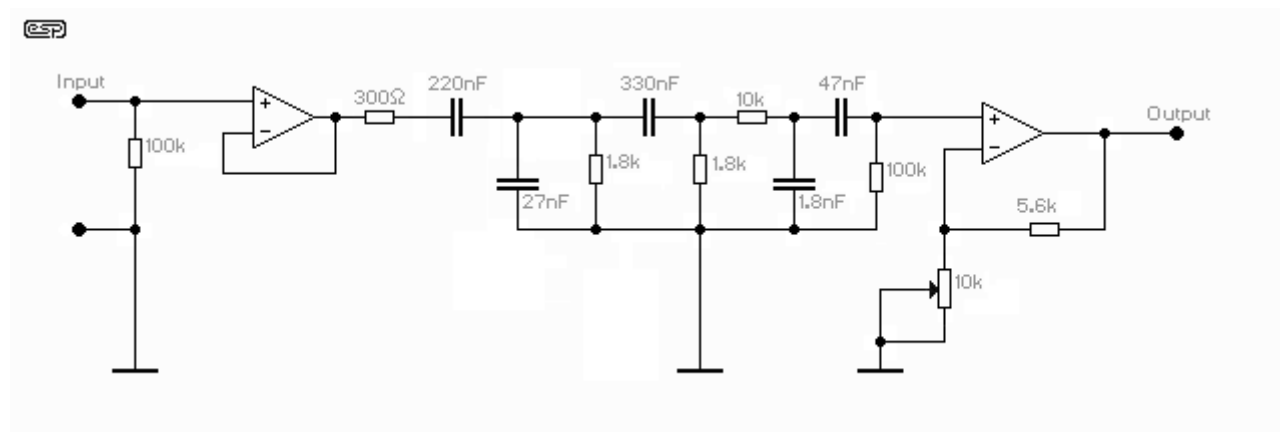

Figure 3 - The A-Weighting Filter Schematic

I will leave it up to the reader to decide on the opamps - I suggest a TL072 dual FET device or similar, which should be ok for most applications (they are not too bad for general purpose work). No opamp pinouts have been included, these are available on any manufacturers' data sheet if you don't know them.

Basic calibration is not hard - the overall gain at 2,700Hz is supposed to be about 1.3dB, so if the input is set to 1V RMS, the output at 2.7kHz should be 1.162V. Alternatively, at 1kHz, the gain (or insertion loss) should be 0dB - I would suggest that it is checked at both frequencies if possible, and if necessary, average the error between the two frequencies.

Use the 10k trimpot to adjust the level (you need to be accurate with your measurements if true A-weighting is to be obtained). Note that the trimpot should be a quality multi-turn "Cermet" (Ceramic-Metal Film) type to enable accurate setting and long-term stability. Alternatively the trimpot may be replaced with a 5.6k resistor, and accuracy will be quite acceptable for most applications (the error is less than 0.2dB).

So, there you have it. This project will enable you to make "industry standard" measurements of amplifier noise levels, it is up to you to decide which particular standard you want to make comparisons against. Life would be so much easier if all noise measurements were made "flat" - with no filters of any kind, but this is not to be.

Update - 29 Aug 2002

The filter as originally shown was a little off at 2.7kHz relative to 1kHz (it should be 1.3dB higher at the higher frequency), and this has been corrected. The version shown should be accurate to within about 0.1dB.

It was pointed out (May 2000) that the curve of the original filter shown is not a very good fit to more modern measurement sets, and a small modification will cure this. The low frequency response of the original was not quite what it should be, and at high frequencies the rolloff was too slow. The circuit now shows the original updated version (as well as the latest update), which is more accurate than the original.