

Electronic Projects Online - Graphic Equaliser

Originally published by Paul Stenning in Electronics in Action, April 1994

When I designed this unit I wrote a little program in QuickBasic to calculate the gyrator component values. I have now found a copy on an old backup disk and have included it on this website. A link to the download file (includes source code and .exe file) is in the list below.

Steven Dumon suggests the use of a TL074 dual op-amp in place of the LF347 (which is apparently now difficult to obtain).

A problem I frequently encounter when copying video tapes is the deterioration in the sound quality. The five band graphic equaliser described here was designed to connect between two video recorders, so that the frequency response can be corrected somewhat. Its use is by no means limited to video recording however, it is a general purpose design that will prove useful for many audio applications.

The five controls each have a range of +/- 10dB at centre frequencies of 100Hz, 300Hz, 1KHz, 3KHz and 10KHz. The 3dB points on each band are at half and twice the centre frequencies. Thus, the 3dB points on the 100Hz control are at 50Hz and 200Hz. With all controls at maximum the unit has a total gain of 15dB. The unit will accept an input of up to about 1V RMS (3V pk-pk) before distortion occurs with all controls at maximum.



I do not possess suitable test equipment to measure noise and distortion, although none was apparent on the oscilloscope trace. I would describe the unit as suitable for good quality stereo equipment, but not true hi-fi.

Although the design is mono, a stereo version could be built using two PCB's and stereo pots. More details on this are given later.

The Works

The complete circuit diagram is shown in figure #. This basic circuit principle has been used in several graphic equaliser designs, so I am making no great claims about its originality!

The input is buffered by the first section of IC1, which has unity gain and a consistent output impedance. If any overall gain or attenuation is required, it may be achieved by altering the values of R1 to R4.

To make the explanation of the second stage clearer, assume that all five frequency selective sections have disappeared, as well as four of the control pots. The wiper of the remaining pot is connected to ground via a 1K0 resistor.

If the pot is in the upper position (fully clockwise), the 1K0 resistor appears between the inverting input of the op-amp and ground, giving the stage a gain of ten. If the pot track resistance is 10K (five 50K pots in parallel), the signal at the non-inverting input is halved, giving a total gain of five.

With the pot in the lower position (anti-clockwise), the input to the non-inverting input is reduced to a tenth, and the gain of the op-amp circuit is two, giving a total gain of a fifth.

With the pot in the centre the gain of the whole stage is unity, since the attenuation of the input signal is cancelled by the gain of the op-amp. If our imaginary 1K0 resistor is replaced with a tuned circuit, the effects described above will only occur around its centre frequency. In this circuit we have five tuned circuits giving the five bands.

Traditionally the tuned circuits would consist of a capacitor and inductor in series. Due to the lack of availability of suitable inductors, modern designs use a gyrator circuit to simulate an inductor. This uses an op-amp to reverse the phase relationship of a capacitor, to make it appear like an inductor.

Taking the first stage, C4 is the real capacitor and the op-amp and remaining components form the gyrator. The R7 controls the reactance of our "inductor", and therefore the Q of the tuned circuit. In this case we do not want a particularly sharp response so the Q is fairly low. R7, R8 and C3 all affect the "inductance", and I have yet to find the correct formula for calculating this!

The final output of the circuit is buffered by a unity gain op-amp stage. SW1 selects whether the equaliser is in the audio path.

The circuit requires a supply of +/-12 to 15V, at less than 10mA. This does not need to be regulated but must be smooth and have minimal ripple. The output of a 9-0-9 transformer is full wave rectified and smoothed giving approximately +/-13V across the 220uF capacitors. About a volt is dropped by the 100R decoupling resistors, leaving around 12V to power the circuit.

Construction

All the components, except the transformer and pots, are mounted on a single sided PCB, 113mm * 51mm. The component overlay is shown in figure #.

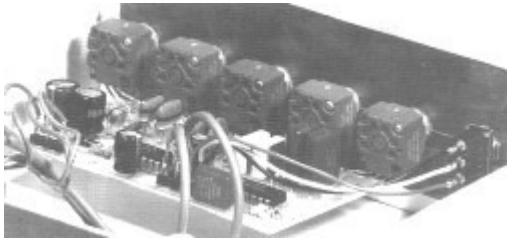

There are two wire links that should be fitted first, along with the resistors and diodes. The remaining components may then be fitted. Sockets may be used for the IC's, but this is not really necessary providing they are fitted last and soldered carefully.

The non-polarised capacitors should be reasonable quality types, dipped polyester or mylar types are suitable. Try to avoid the cheap ceramic disk types, for this project. The PCB holes for these components are on a 0.4" pitch, which is suitable for the suggested types.

Two PCBs are required for a stereo unit. Do not fit D1-D4, C12 and C13, on one PCB.

The prototype had rotary pots, and was constructed in a plastic case that matched my other projects. Many constructors may prefer a more orthodox layout, with slider controls and an instrument or desk case.

Whatever case is used, the PCB's should be mounted as close as possible to the control pots. Use short lengths of wire to connect the pot tags directly to the PCB pads. On the PCB, the left pad for each pot is the minimum or anti-clockwise end of the track, the centre pad is the wiper, and the right pad is the maximum or clockwise end.

Connect the input socket to the SK1 pads, and the output socket to SK2. In both cases the centre core of the screened cable goes to the left pin. The IN/OUT switch connects to the SW1 pads, with the wiper to the centre pad.

The transformer may now be connected to the X1 pads on the PCB, with the centre tap to the middle pad. For a stereo unit, connect the transformer to the PCB with the diodes fitted, and link the SK3 pads on the two boards together. The mains input flex may be joined to the transformer primary wires with a choc-block connector or similar.

Testing and Operation

There is nothing to set up on this unit, it will either work or fail depending on how well it was put together! These few checks with a test meter will confirm that everything is reasonably OK, before connecting the unit to your audio equipment.

First set the test meter to the 20V range, and check the supplies on one of the IC's. There should be about +12V on pin 4 and -12V on pin 13. Now connect the meter to the output (pin 1 of IC1), the voltage should be 0V or thereabouts. Turn each of the five pots to both ends, and check the output remains at almost 0V. If the output is not at 0V (+/- 0.1V) something is wrong, which should be investigated. Now connect the unit to your audio equipment, cross your fingers, and try it.

If the output of this unit is connected to a video recorder or some other piece of equipment with an automatic level control, you may find that the sound level drops if the 100Hz or 300Hz controls are turned up too far. Most automatic level circuits respond more to the bass frequencies.

Bearing this in mind, faint and grotty recordings can sometimes be avoided by turning the 100Hz and 300Hz bands down a bit to reduce the effect of the level control. Turn the 1KHz and 3KHz up a bit to improve the clarity, and turn the 10KHz down to get rid of any hiss. The result may sound a bit thin, but it is better than a quiet muffled sound with tape hiss.

There's not much else I can say about using this unit. Most people know what a graphic equaliser does, and a little trial and error will show the effect of each frequency band.

Parts

Resistors (0.25W 5% or better)

| | |
|----------------|---------|
| R1,2 | 47K |
| R3,4,5,6 | 10K |
| R7,9,11,13,15 | 1K2 |
| R8,10,12,14,16 | 18K |
| R17,18 | 100R |
| VR1,2,3,4,5 | 50K Pot |

Capacitors

| | |
|------|------|
| C1 | 470n |
| C2,3 | 330n |
| C4,5 | 100n |
| C6,7 | 33n |

| | |
|--------|----------|
| C8,9 | 10n |
| C10,11 | 3n3 |
| C12,13 | 220u 16V |
| C14,15 | 100u 16V |

Semiconductors

| | |
|----------|------------------------------|
| IC1,2 | LF347 (or TL074 dual op-amp) |
| D1,2,3,4 | 1N4001 |

Miscellaneous

9-0-9V 100mA Transformer, PCB, Case, Knobs, SPDT Switch, Two Phono Sockets, Screened Cable, Wire, Mains Flex.

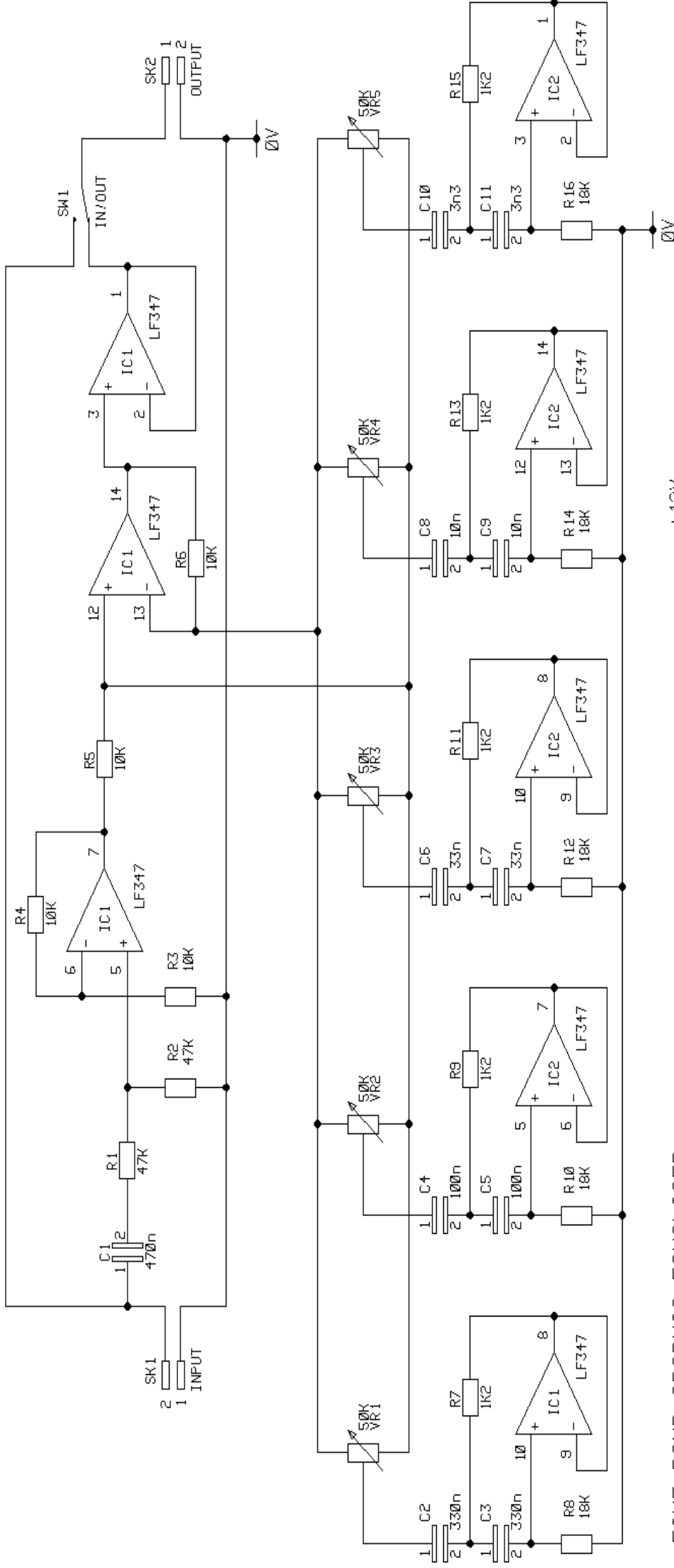

FIVE BAND GRAPHIC EQUALISER
 (C) PAUL STENNING 1994

